

# Throttle Control Cable Bracket



# Throttle Control Cable

## Adjustment (Carbureted Engine)

## Adjustment/Inspection (Carbureted Engine)

1. Disconnect the throttle control cable from the throttle control lever.
2. Bend down the lock tabs of the lock plate and remove the two 6 mm bolts to free the bracket.
3. Loosely install a new lock plate.
4. Position the special tool between the throttle control lever and the bracket as shown.

NOTE: The special tool is designed so that the distance between the lever and the bracket is 157.0 mm (6.18 in.) when it is installed.

5. Position the bracket so that there is no binding between the bracket and the special tool (tolerance 0 to + 0.3 mm). Then tighten the two 6 mm bolts, bend up the lock plate tabs against the bolts heads.

**CAUTION:** Make sure the control lever doesn't get pulled toward the bracket side as you tighten the bolts.

NOTE: Perform the following inspections before adjusting the throttle control cable.

- The carburetor throttle cable play is correct. See Fuel Section.
- The engine is warmed-up to operating temperature.

NOTE: The cooling fan should come on twice or more.

- The idle speed is correct. (See Section 6).
- The automatic choke operation is correct. See "Throttle Control Cable Bracket Adjustment."
- The distance between the throttle control lever and the throttle control bracket is correct. See "Throttle Control Cable Bracket Adjustment."

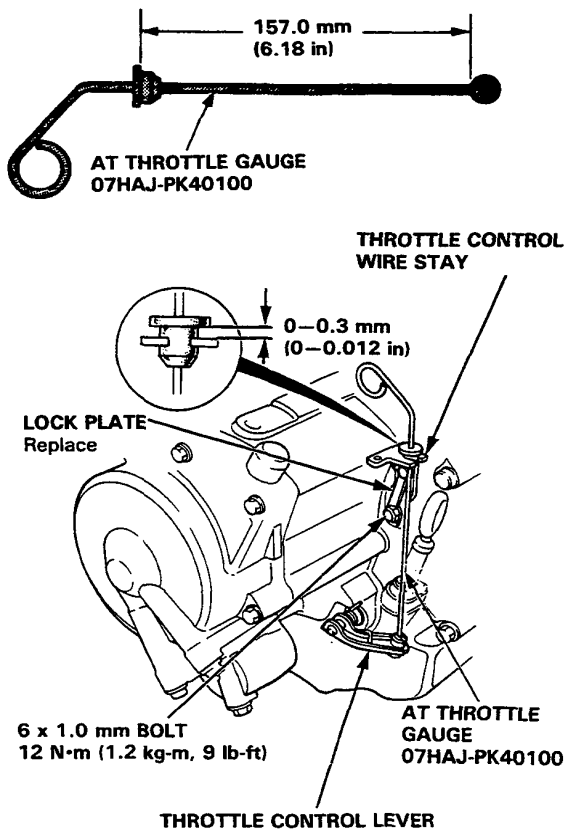

1. Disconnect the vacuum tube from the dash pot, connect the vacuum pump and keep vacuum applied. (page 9-36). This simulates a normal operating amount of pull by the dash pot as if the engine were running.
2. Attach a weight of about 1.5 kg (3 lbs) to the accelerator pedal. Raise the pedal, then release it, this will allow the weight to remove the normal free play from the throttle cable.

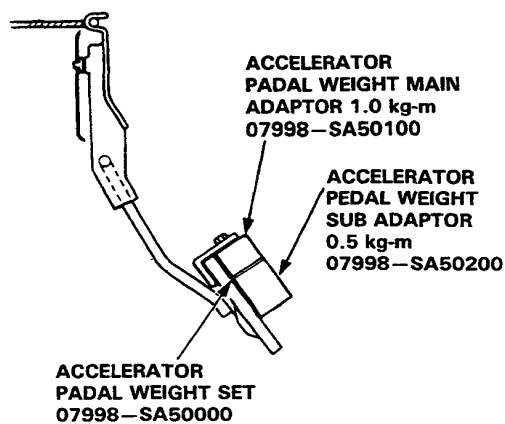

(cont'd)

# Throttle Control Cable

## Adjustment/Inspection (Carbureted Engine)

3. Secure the throttle control cable with clamps as shown.
4. Lay the end of the throttle control cable on the shock tower.
5. Adjust the distance between the throttle control cable end and nut (A) to 158.0 mm (6.22 in) (LHD)/157.5 mm (6.20 in) (RHD).

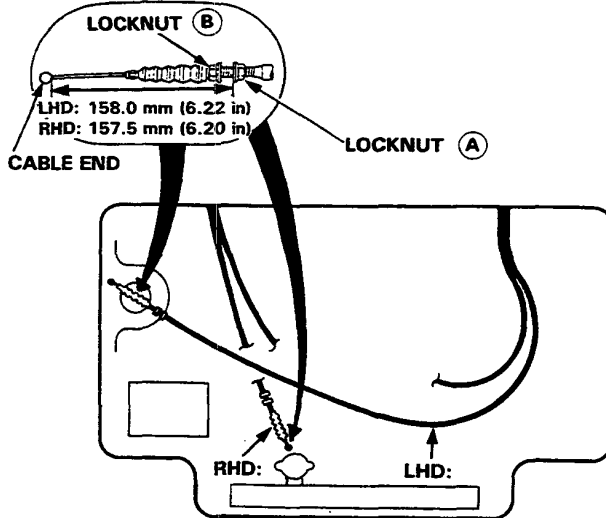

6. Insert the end of throttle control cable in the groove of the throttle control lever.

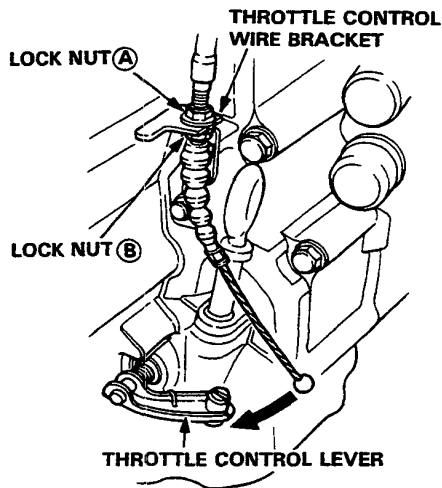

7. Insert the throttle control cable in the bracket and secure with locknut (B).

NOTE: Make sure the cable is not kinked or twisted.

8. Check that the cable moves freely by depressing the accelerator.
9. Remove the weight on the accelerator pedal and push the pedal to make sure that there is the specified play at the throttle control lever.

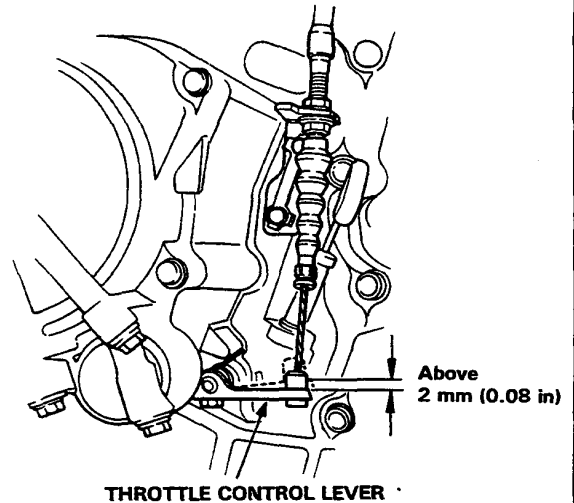

10. Start the engine and check the synchronization between the carburetor and the throttle control cable.

NOTE: The throttle control lever should start to move as engine speed increases.

- If the throttle control lever moves before engine speed increases, turn the cable locknut A counter clockwise and tighten locknut B.
- If the throttle control lever moves after engine speed increases, loosen locknut B, turn locknut A clockwise and tighten the locknut B.

(cont'd)



# Throttle Control Cable

## Adjustment/Inspection (cont'd) (Fuel-Injected Engine)

1. Loosen locknuts (A) and (B) on the throttle control cable.
2. Press down as shown on the throttle control lever until it stops.

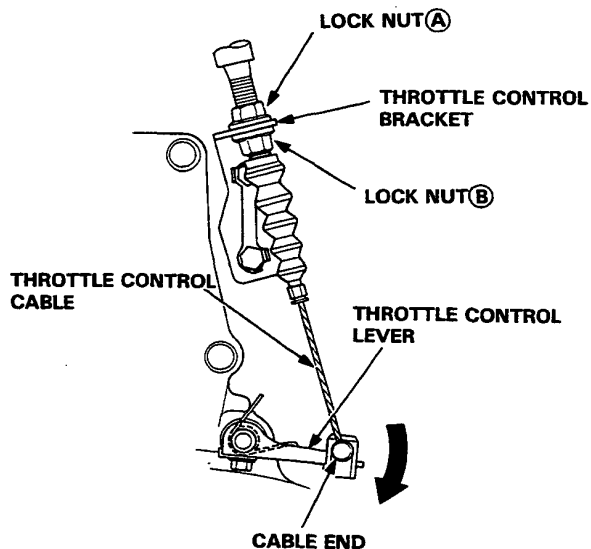

3. While pressing down on the throttle control lever, pull on the throttle link to check the amount of throttle control cable free play.

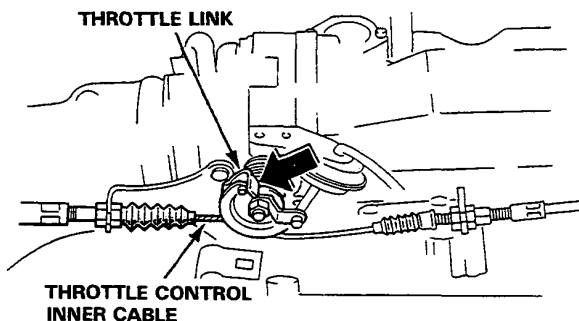

Remove all throttle control cable free play by gradually turning lock nut "A."

Until no movement can be felt in the throttle link, while continuing to press down on the throttle control lever, pull open the throttle link. The control lever should begin to move at precisely the same time as the link.

**NOTE:** Correct "Fine Tune" adjustment of the throttle control cable is critical for proper operation of the transmission and lock-up torque convertor.

4. Check the following items before starting the engine:

Depress the accelerator to the floor. While depressed, check that there is play in the throttle control lever.

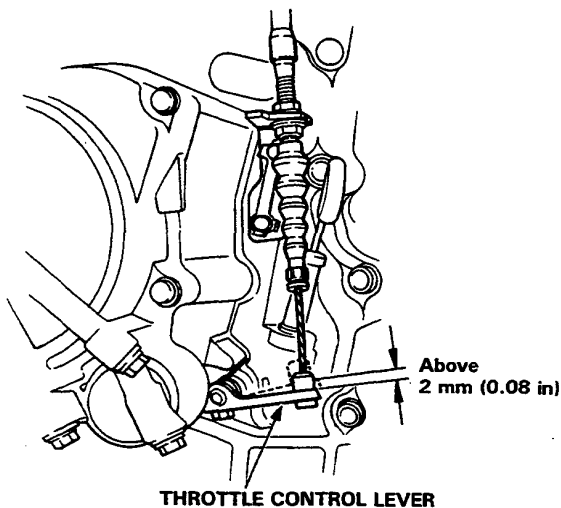

- Check that the cable moves freely by depressing the accelerator.