

Component Locations

Carbureted engine:

LHD:

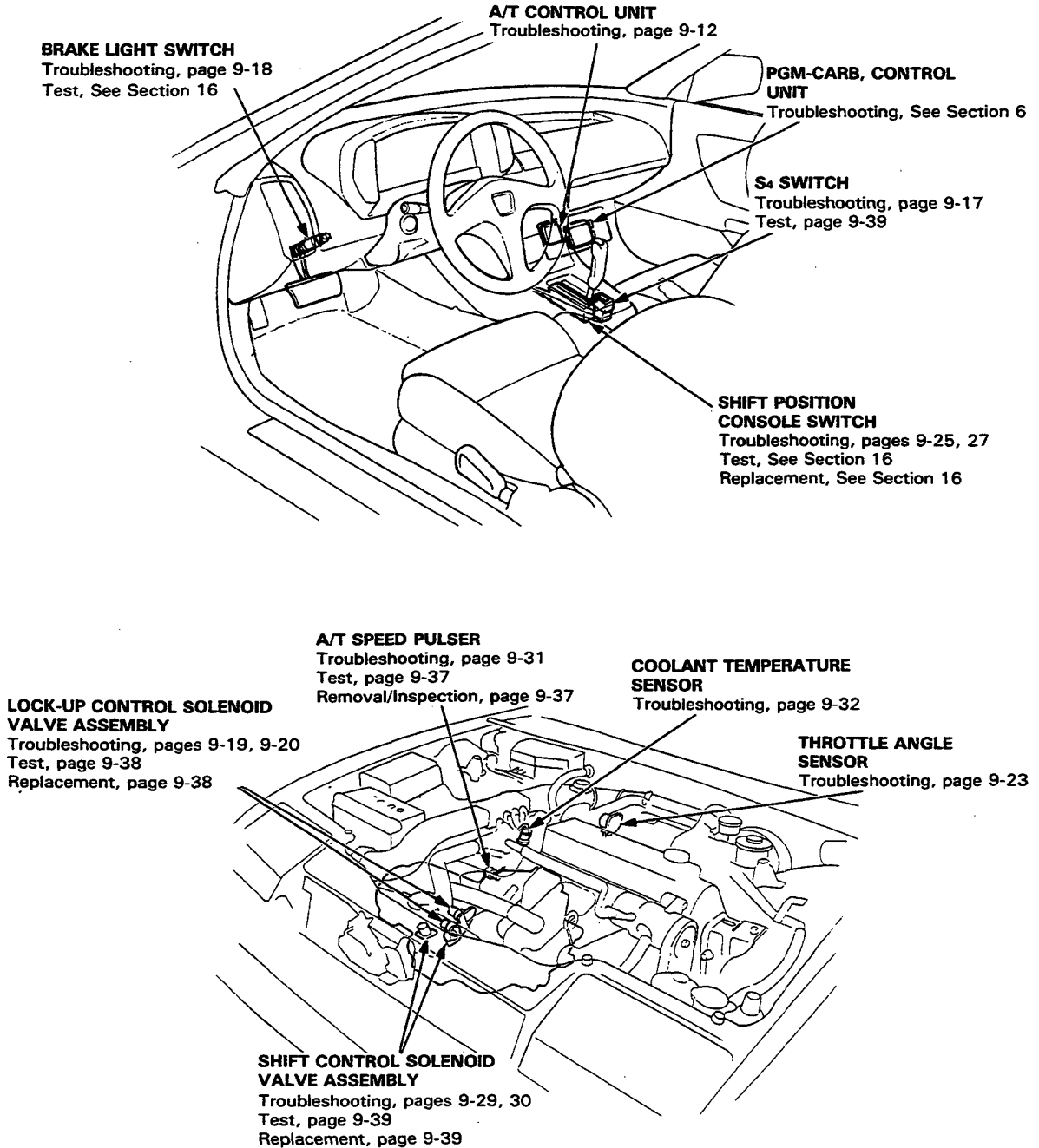



RHD:

PGM-CARB, CONTROL UNIT

Troubleshooting, See Section 6

A/T CONTROL UNIT

Troubleshooting, page 9-12

BRAKE LIGHT SWITCH

Troubleshooting, page 9-18
Test, See Section 16

S₄ SWITCH

Troubleshooting, page 9-17
Test, See page 9-39

**SHIFT POSITION
CONSOLE SWITCH**

Troubleshooting, pages 9-25, 27
Test, See Section 16
Replacement, See Section 16

A/T SPEED PULSER

Troubleshooting, page 9-31
Test, page 9-37
Removal/Inspection, page 9-37

**COOLANT TEMPERATURE
SENSOR**

Troubleshooting, page 9-32

**LOCK-UP CONTROL SOLENOID
VALVE ASSEMBLY**

Troubleshooting, pages 9-19, 20
Test, page 9-38
Replacement, page 9-38

**THROTTLE ANGLE
SENSOR**

Troubleshooting, page 9-23

**SHIFT CONTROL SOLENOID
VALVE ASSEMBLY**

Troubleshooting, pages 9-29, 30
Test, page 9-39
Replacement, page 9-39

Component Locations

Fuel-Injected engine:

LHD:

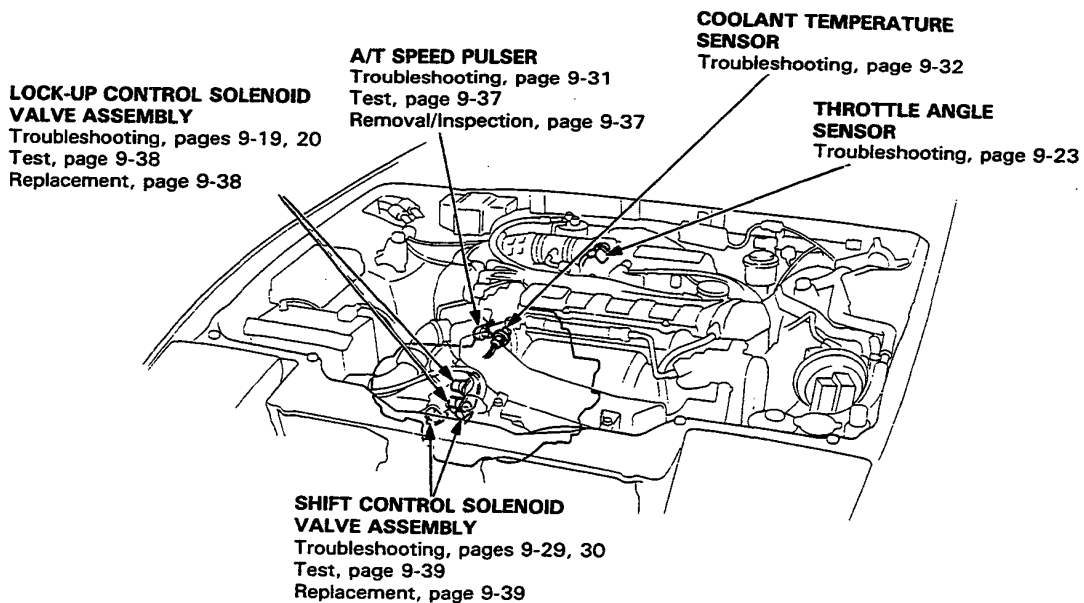
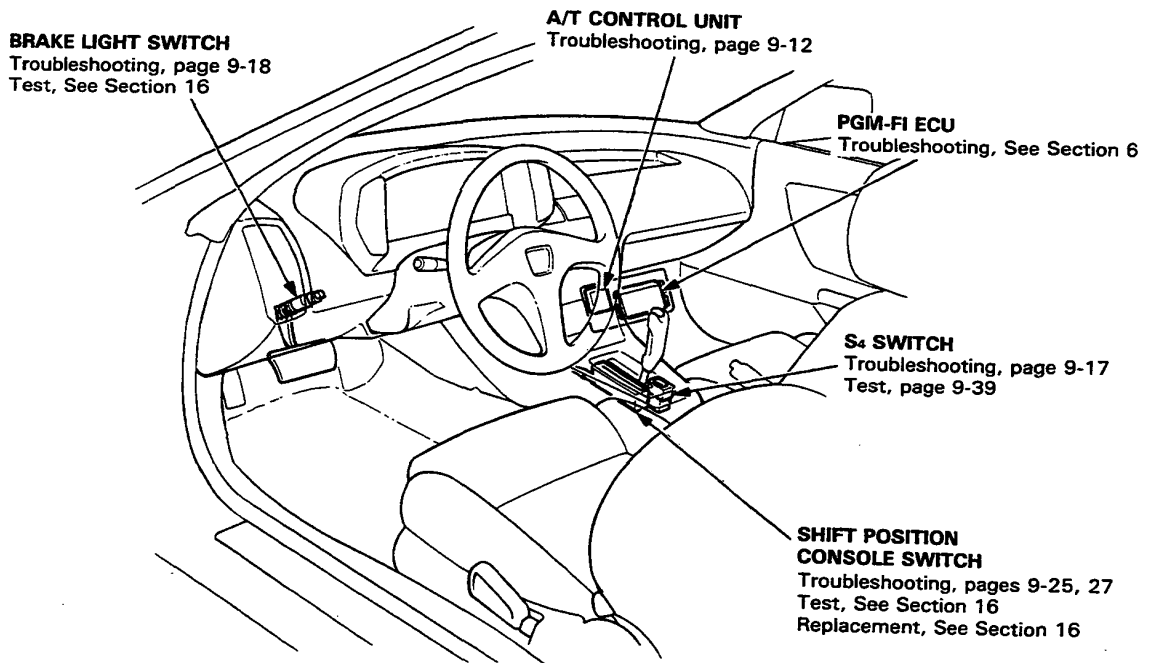



RHD:

PGM-FI ECU
Troubleshooting, See Section 6

A/T CONTROL UNIT
Troubleshooting, page 9-12

BRAKE LIGHT SWITCH
Troubleshooting, page 9-18
Test, See Section 16

S₄ SWITCH
Troubleshooting, page 9-17
Test, page 9-39

**SHIFT POSITION
CONSOLE SWITCH**
Troubleshooting, pages 9-25, 27
Test, See Section 16
Replacement, See Section 16

A/T SPEED PULSER
Troubleshooting, page 9-31
Test, page 9-37
Removal/Inspection, page 9-37

**LOCK-UP CONTROL SOLENOID
VALVE ASSEMBLY**
Troubleshooting, pages 9-19, 20
Test, page 9-38
Replacement, page 9-38

**COOLANT TEMPERATURE
SENSOR**
Troubleshooting, page 9-32

**THROTTLE ANGLE
SENSOR**
Troubleshooting, page 9-23

**SHIFT CONTROL SOLENOID
VALVE ASSEMBLY**
Troubleshooting, pages 9-29, 30
Test, page 9-39
Replacement, page 9-39