

Valve Clearance Adjustment

Fuel-Injected Engine:

NOTE: Valves should be adjusted cold when the cylinder head temperature is less than 38°C (110°F). Adjustment is the same for intake and exhaust valves.

1. Remove the valve cover.

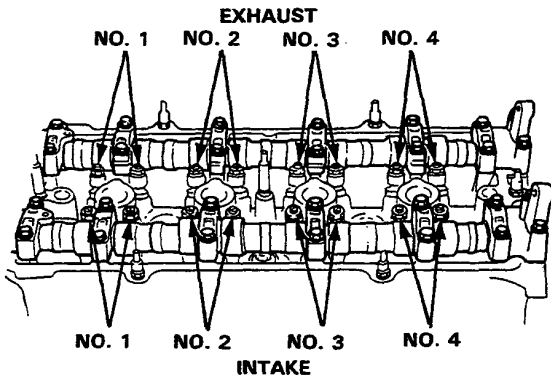

2. Set the No. 1 piston at TDC. "UP" marks in the pulleys should be at top, and the TDC grooves on back side of pulley should align with cylinder head surface. The distributor rotor must be pointing towards No. 1 plug wire.

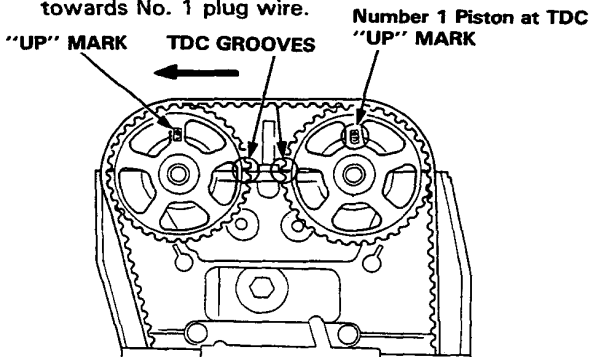

3. Adjust valves on No. 1 cylinder.
Intake: 0.08–0.12 mm (0.003–0.005 in.)
Exhaust: 0.16–0.20 mm (0.006–0.008 in.)
4. Loosen locknut and turn adjust screw until feeler gauge slides back and forth with slight amount of drag.

LOCKNUT 7 x 0.75 mm
25 N·m (2.5 kg·m, 13 lb·ft)

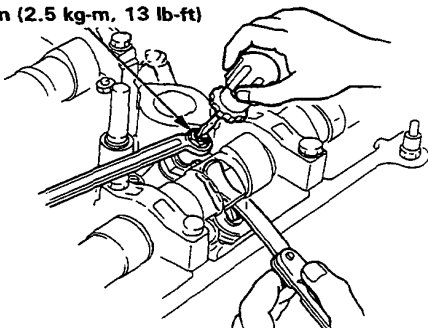

5. Tighten locknut and check clearance again. Repeat adjustment if necessary.
6. Rotate crankshaft 180° counterclockwise (cam pulley turns 90°). The "UP" marks should be at exhaust side. Distributor rotor should point to No. 3 plug wire. Adjust valves on No. 3 cylinder.

Number 3 piston at TDC

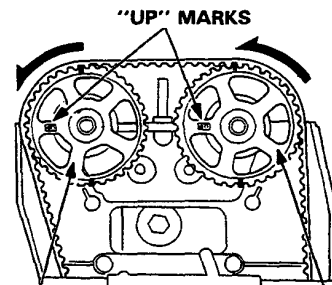

7. Rotate crankshaft 180° counterclockwise to bring No. 4 piston to TDC. Both "UP" marks should be at bottom and distributor rotor points to No. 4 plug wire. Adjust valves on No. 4 cylinder.

Number 4 piston at TDC

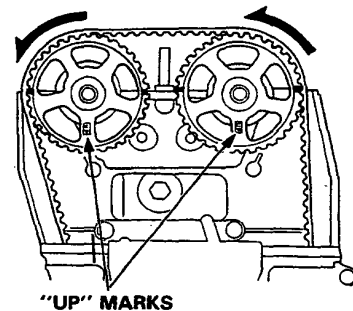

8. Rotate crankshaft 180° counterclockwise to bring No. 2 piston to TDC. "UP" marks should be at intake side. Distributor rotor should point to No. 2 plug wire. Adjust valves on No. 2 cylinder.

Number 2 piston at TDC

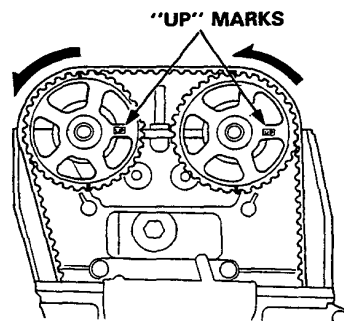



Carbureted Engine:

NOTE: Valves should be adjusted cold when the cylinder head temperature less than 38°C (100°F). Adjustment is the same for intake and exhaust valves.

1. Remove valve cover.

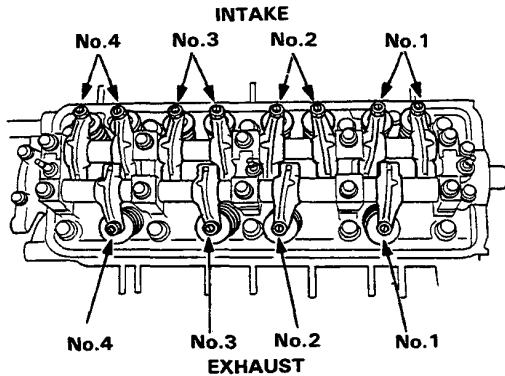

2. Set No.1 piston at TDC. "UP" mark in pulley should be at top, and TDC grooves on back side of pulley should align with cylinder head surface. The distributor rotor must be pointing towards No. 1 plug wire.

Number 1 Piston at TDC
"UP" MARK

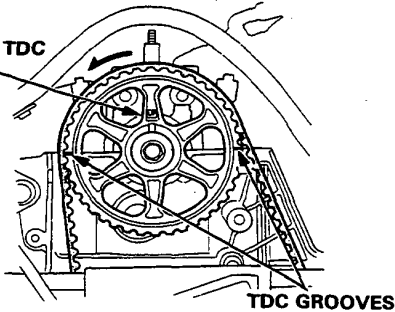

- Adjust valves on No.1 cylinder.
Intake: 0.12–0.17 mm (0.005–0.007 in.)
Exhaust: 0.25–0.30 mm (0.010–0.012 in.)
- Loosen locknut and turn adjustment screw until feeler gauge slides back and forth with slight amount of drag.

INTAKE and EXHAUST VALVE
LOCKNUTS 7 x 0.75 mm
20 N·m (2.0 kg·m, 14 lb·ft)

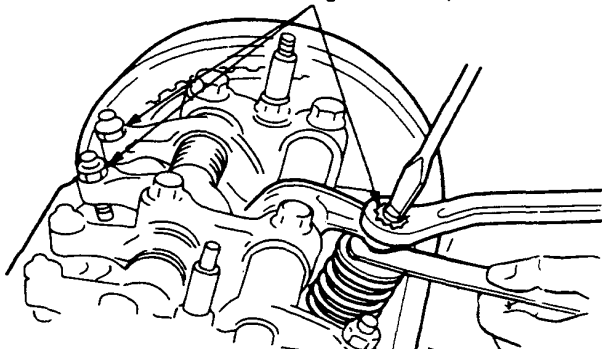

- Tighten locknut and check clearance again. Repeat adjustment if necessary.
- Rotate crankshaft 180° counterclockwise (cam pulley turns 90°). The "UP" mark should be at exhaust side. Distributor rotor should point to No. 3 plug wire. Adjust valves on No. 3 cylinder.

Number 3 piston at TDC

"UP" MARK

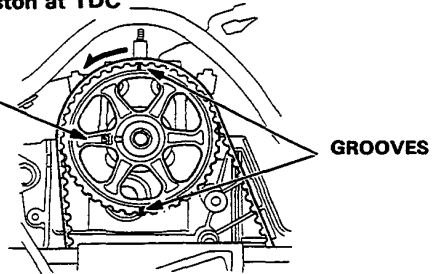

- Rotate crankshaft 180° counterclockwise to bring No. 4 piston to TDC. Both TDC grooves are once again visible and distributor rotor points to No.4 plug wire. Adjust valves on No.4 cylinder.

Number 4 piston at TDC

"UP" MARK

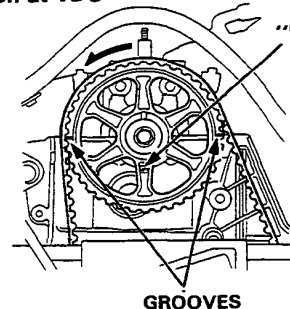

- Rotate crankshaft 180° counterclockwise to bring No. 2 piston to TDC. The "UP" mark should be at intake side. Distributor rotor should point to No. 2 plug wire. Adjust valves on No. 2 cylinder.

Number 2 piston at TDC

GROOVES

