

# Engine Removal/Installation

## WARNING

- Make sure jacks and safety stands are placed properly (pages 1-6 thru 8), and hoist brackets are attached to correct positions on the engine (page 5-52).
- Apply parking brake and block rear wheels, so car will not roll off stands and fall on you while working under it.

**CAUTION:** Use fender covers to avoid damaging painted surfaces.

## WARNING

Use care when removing radiator cap and when draining radiator, engine and transmission, to avoid scalding by hot coolant or oil.

1. Disconnect the battery negative terminal first, then the positive terminal.
2. Unbolt the hood brackets and remove the hood after removing the washer hose.

**CAUTION:** Use care when storing the hood to avoid damaging the paint.

3. Remove the drain plug to drain engine oil.
  - Remove the filler cap to speed draining.

**CAUTION:** After draining the engine oil, always replace drain washers with new ones.

## Carbureted Engine:

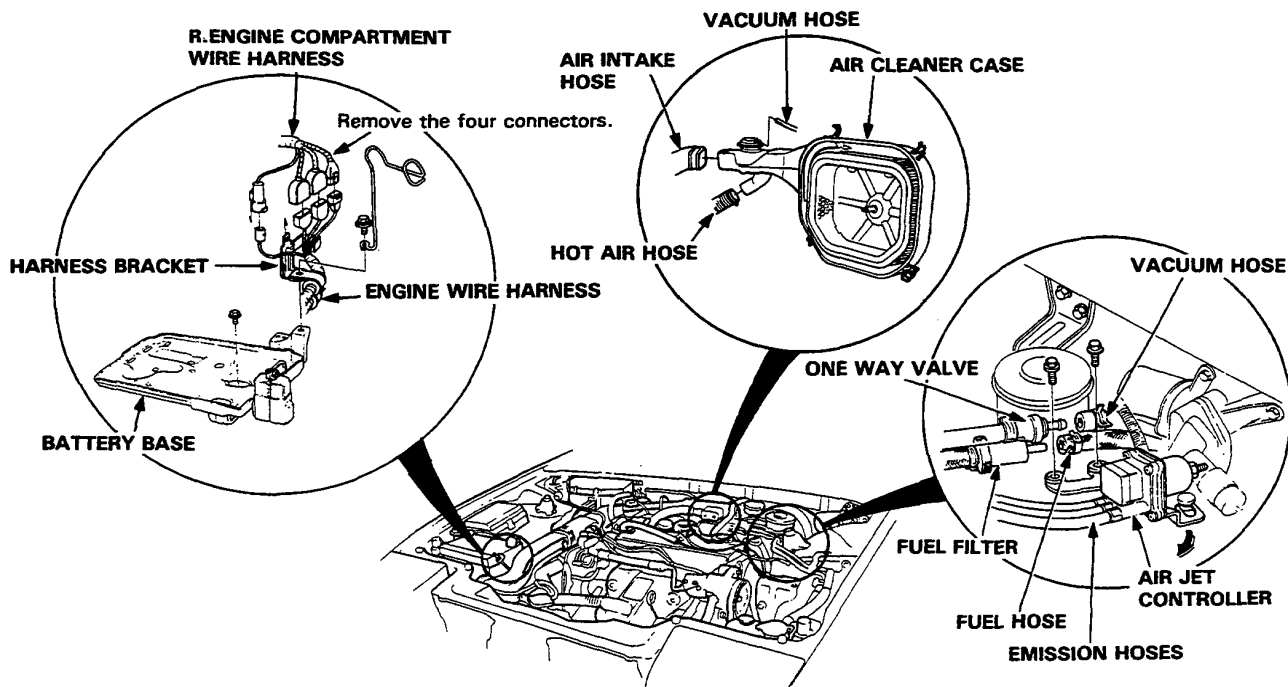

4. Drain transmission oil.
  - Use a 3/8" drive socket wrench to remove the drain plug.
  - Remove the level gauge or filler bolt to speed draining.
5. Loosen the drain plug to drain coolant from the radiator.
  - Remove the radiator cap to speed draining.

**Carbureted Engine (Fuel-Injected Engine, go to step 11.)**

6. Remove the battery and battery base.
7. Remove the air intake hose and air cleaner case.
8. Disconnect the fuel hose at the fuel filter.
  - **WARNING** Do not smoke while working on fuel system. Keep open flame or spark away from work area.
9. Disconnect the brake booster vacuum hose at the one way valve.
10. Remove the air jet controller.
  - Do not disconnect the emission hoses.



**Fuel-Injected Engine (Carbureted Engine, go to step 16)**

- 11. Remove the battery and the battery base.
- 12. Remove the air intake hose air cleaner and resonator hose as an assembly.
- 13. Remove the battery wire from the relay box.
- 14. Relieve fuel pressure.

**WARNING** Do not smoke while working on fuel system, keep open flame or spark away from work area. Drain fuel only into an approved container.

- 15. Disconnect the fuel feed hose and fuel return hose.

- 16. Disconnect the charcoal canister vacuum hose at the throttle valve.
- 17. Disconnect the throttle cable at the throttle body or carburetor.

**NOTE:** Take care not to bend the cable when removing it. Do not use pliers to remove the cable from the linkage. Always replace a kinked cable with a new one.

**Fuel-Injected Engine:**

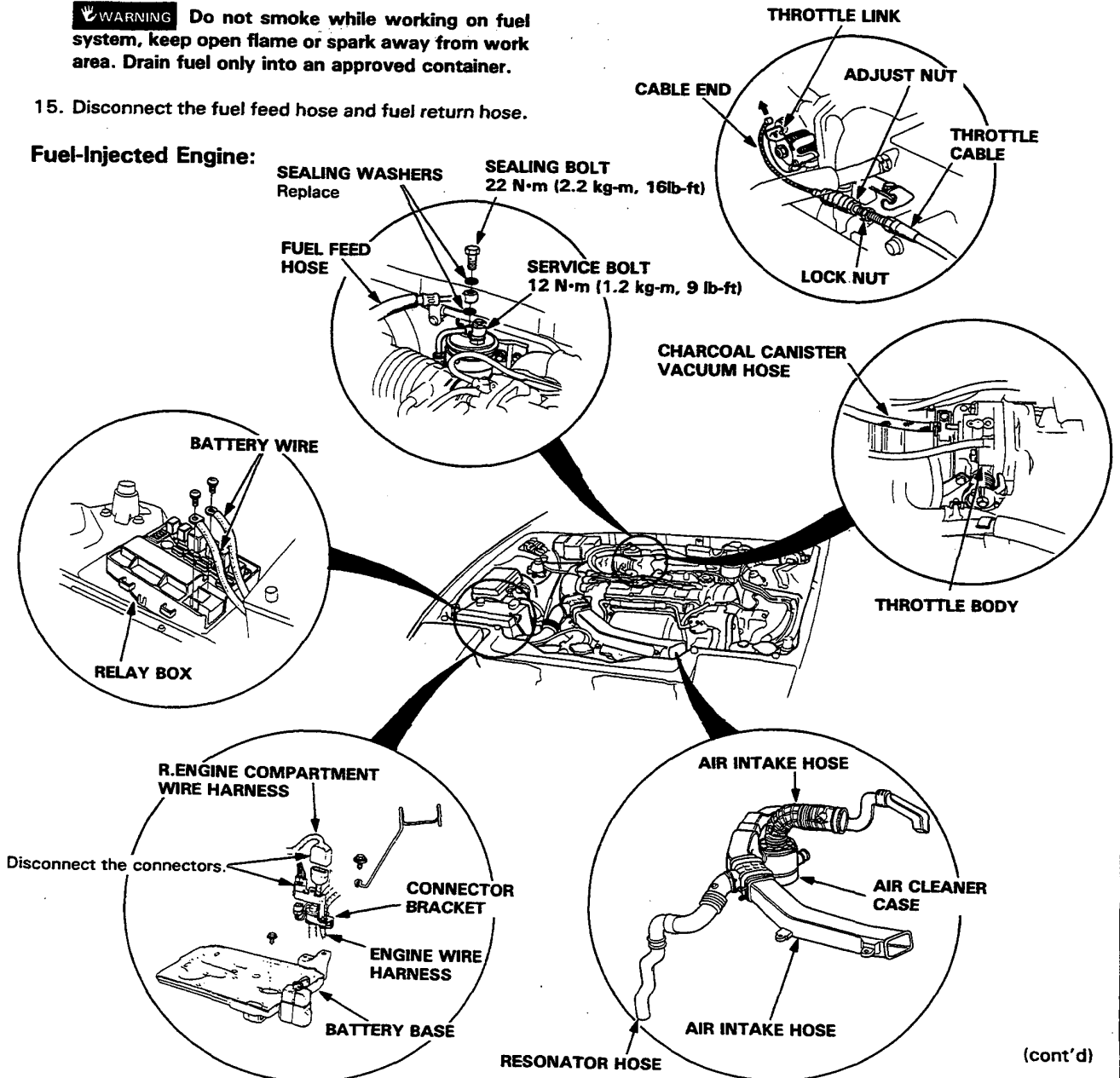

(cont'd)

# Engine Removal/Installation

(cont'd)

18. Disconnect the ignition coil wire, radio noise condenser ground wire and ignition primary connector (Carbureted Engine only), then remove the distributor.

19. Disconnect the upper and lower radiator hoses.

20. Disconnect the inlet and outlet heater hoses.

21. Disconnect the automatic transmission fluid (ATF) cooler hoses (A/T).

- Plug the ATF cooler hoses.

Fuel-Injected Engine shown; Carbureted Engine similar:

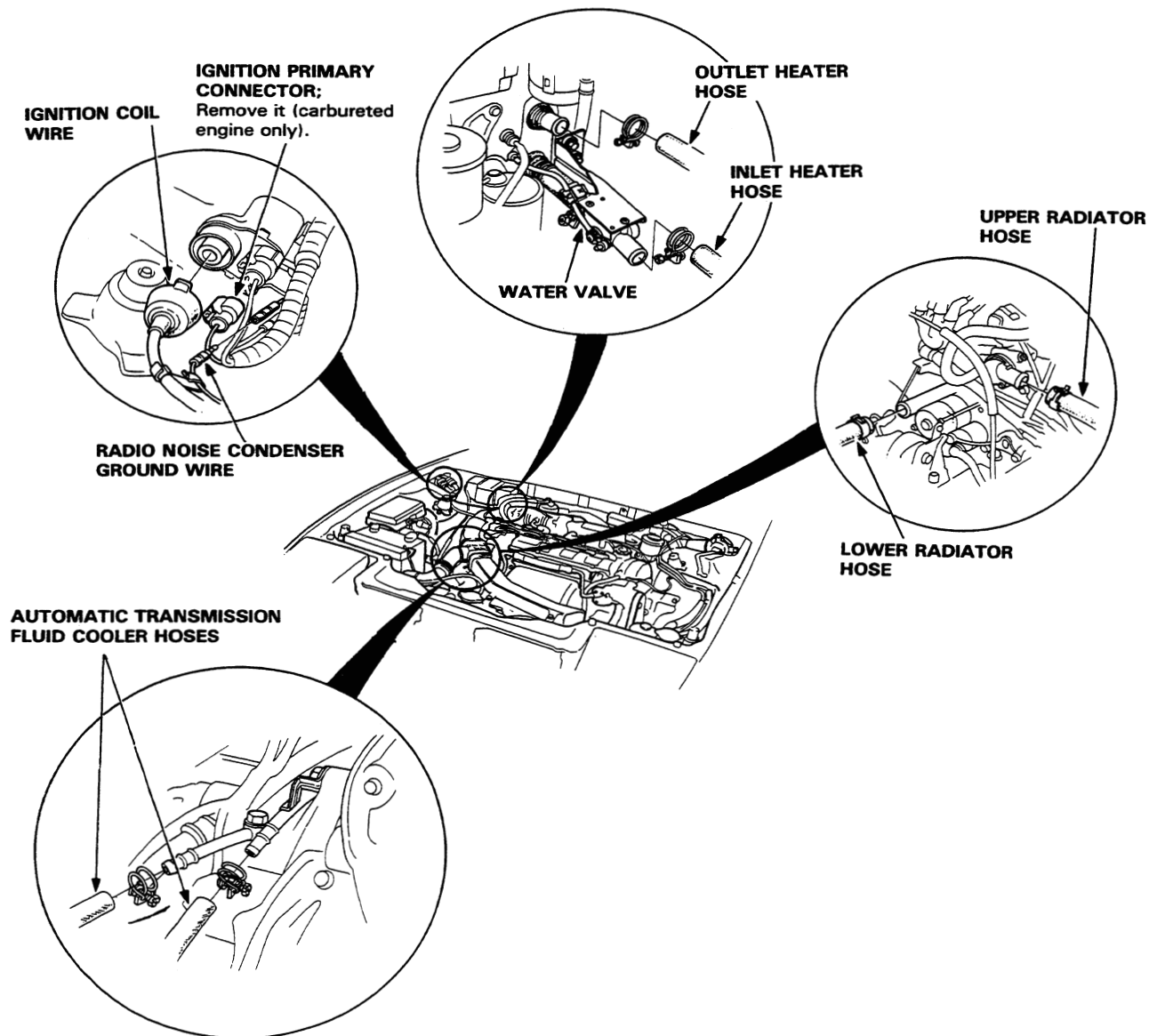



22. Disconnect the engine wire harness connectors from R. engine compartment wire harness (Fuel-Injected Engine only).

**Fuel-Injected Engine:**

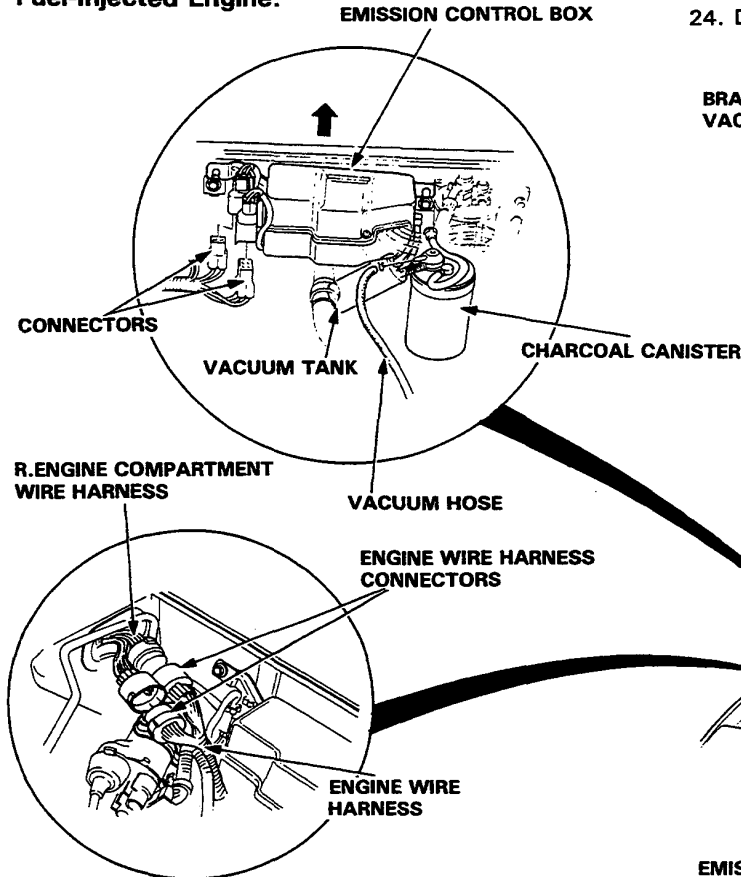

23. Disconnect the two connectors, then remove the emission control box and vacuum tank.

- Don't disconnect the vacuum hoses.

24. Disconnect the brake booster vacuum hose.

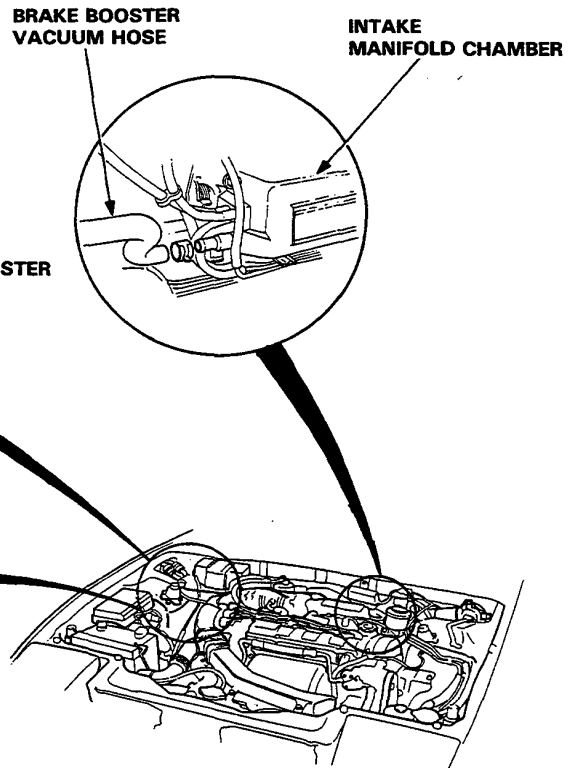

**Carbureted Engine:**

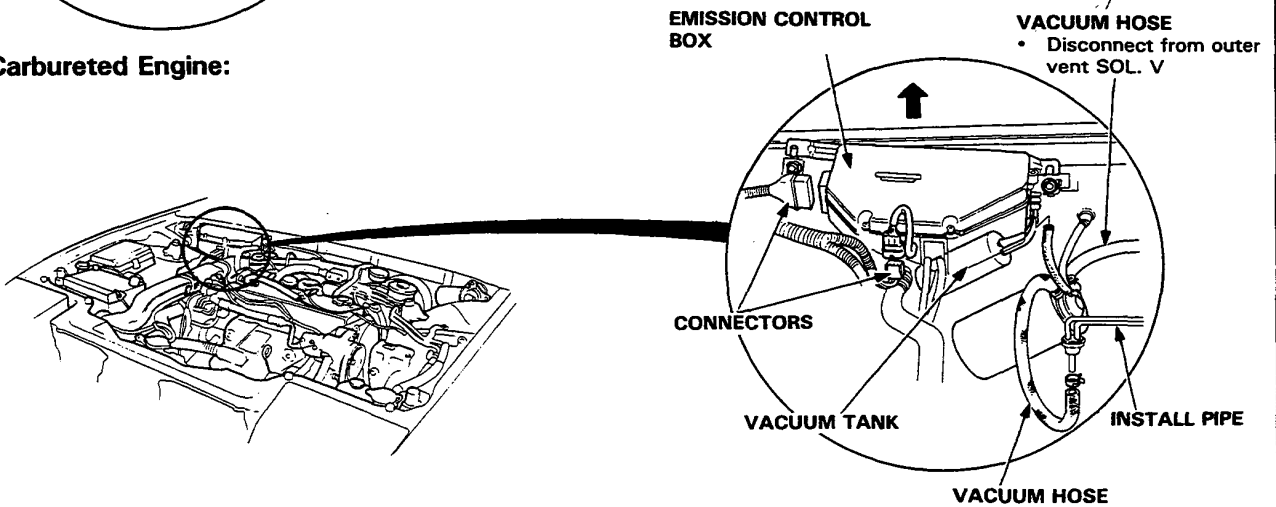

(cont'd)

# Engine Removal/Installation

(cont'd)

25. Remove the power steering (P/S) pump belt and alternator belt (5-24).
26. Disconnect the inlet hose and remove the power steering pump.

**CAUTION:** When the hose is disconnected, fluid will flow out. Cover the alternator with a shop towel.

27. Remove the alternator.
28. Remove the condenser fan shroud.
29. Remove the air conditioning (A/C) compressor, then mount compressor on the front beam (with A/C).
  - Do not disconnect the A/C hoses.

Fuel-Injected Engine shown; Carbureted Engine similar:

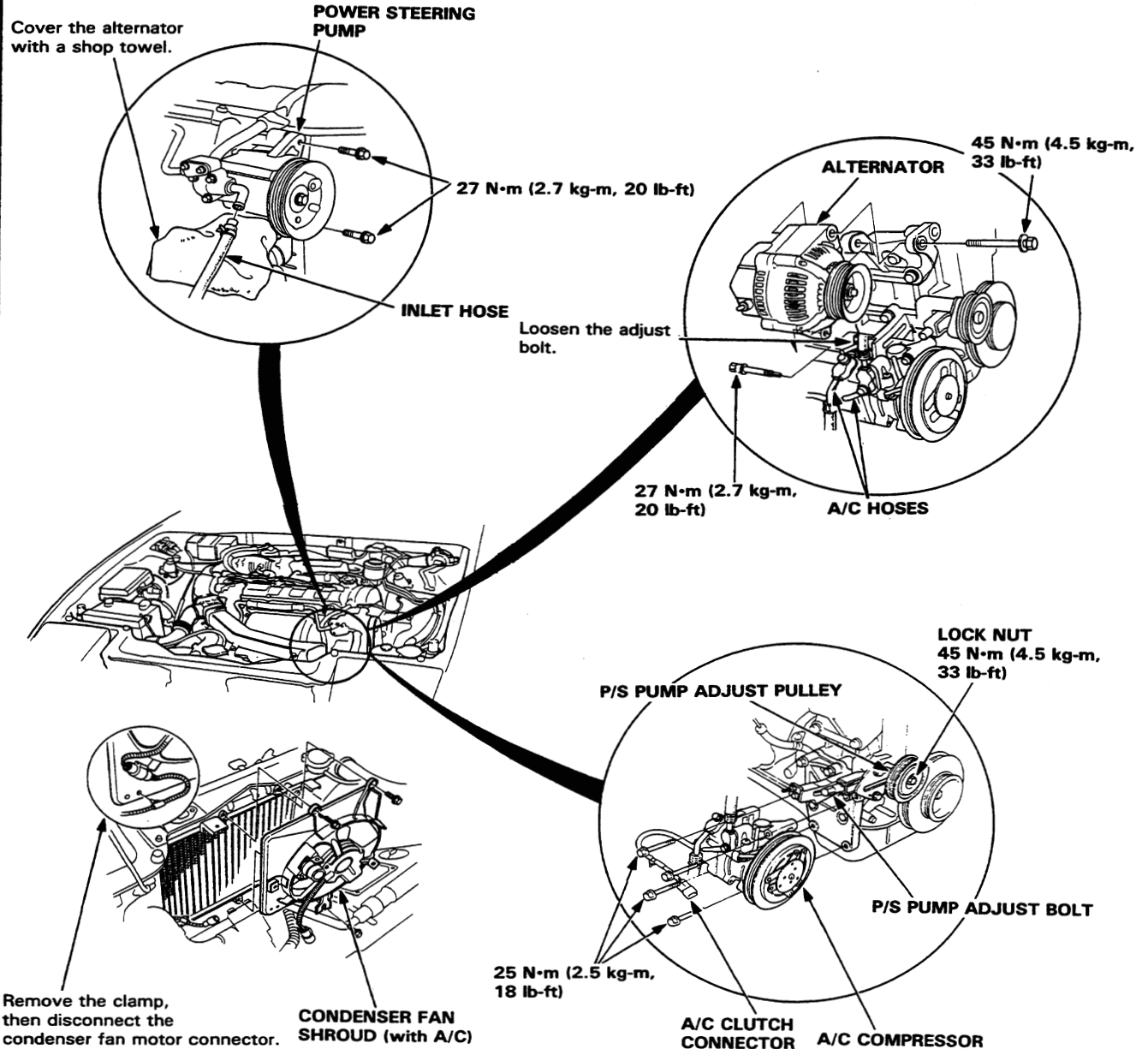



30. Disconnect the shift cable and select cable from the transmission, then remove the cable bracket (M/T).
31. Remove the automatic transmission shift cable from the transmission (A/T).
32. Remove the transmission ground wire.
33. Remove left axle and half shaft.
34. Remove clutch slave cylinder.  
NOTE: Do not disconnect hose from the slave cylinder.

35. Remove speed sensor and speedometer cable.  
NOTE:
  - Take care not to bend the cable when removing it. Do not use pliers to remove the cable. Always replace a kinked cable with a new one.
  - On reassembly, check the cable adjustment (See Section 13 for M/T and Section 14 for A/T).

**Fuel-Injected Engine shown; Carbureted Engine similar:**

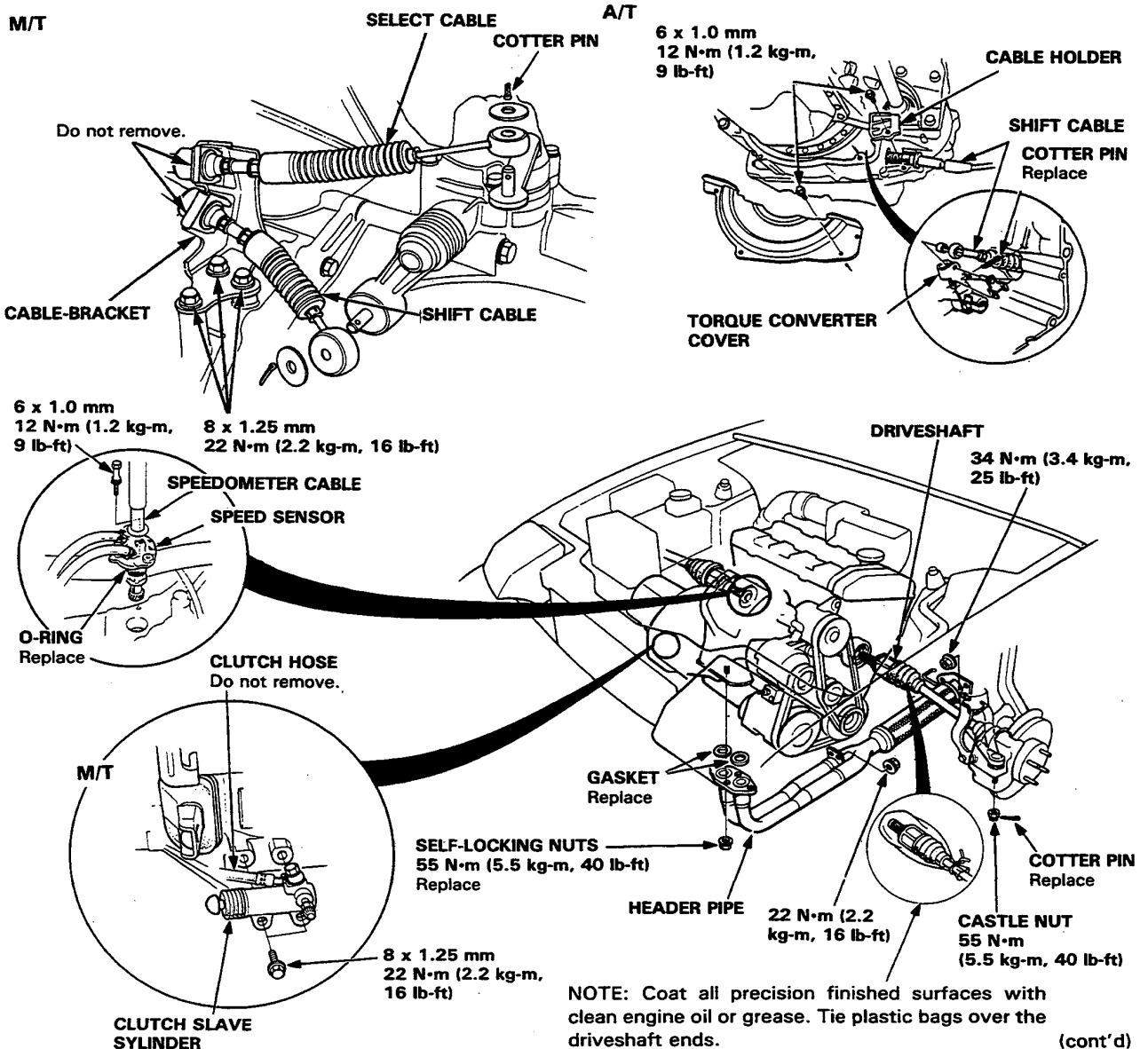

# Engine Removal/Installation

(cont'd)

36. Attach a chain hoist to the engine block and raise the hoist just enough to remove slack from chain.
37. Remove the rear engine mount bolt, then remove the mount bracket.
38. Remove the front engine mount bolt.

**NOTE:** Front and rear engine mount bolts are special bolts. Replace the bolts once they are loosened.

39. Remove the side engine mount bracket bolts.
40. Remove the transmission mount bolt.

41. Check that wires and tubes are completely removed from the engine, and lift the engine slowly with the chain.
42. Tilt the engine, then hoist it out of the engine compartment.

**CAUTION:** Use care to avoid damaging the body.

**WARNING** Do not crawl under the car when hoisting the engine.

**Fuel-Injected Engine shown; Carbureted Engine similar:**

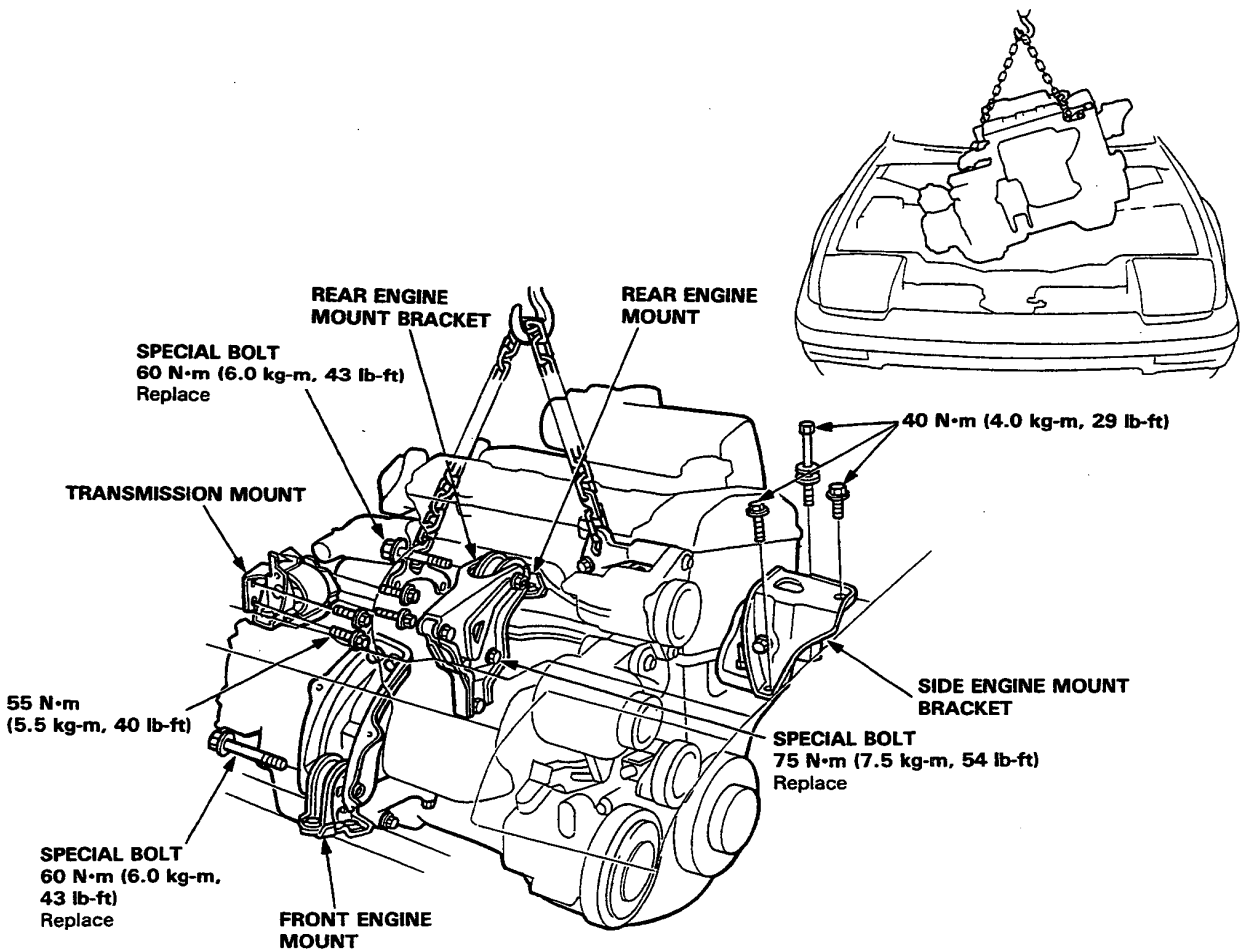



NOTE: For proper suppression of noise and vibration, and maximum bushing life, tighten the bolts in the sequence shown with the bushings centered in their mounts.

**Fuel-Injected Engine shown; Carbureted Engine similar:**

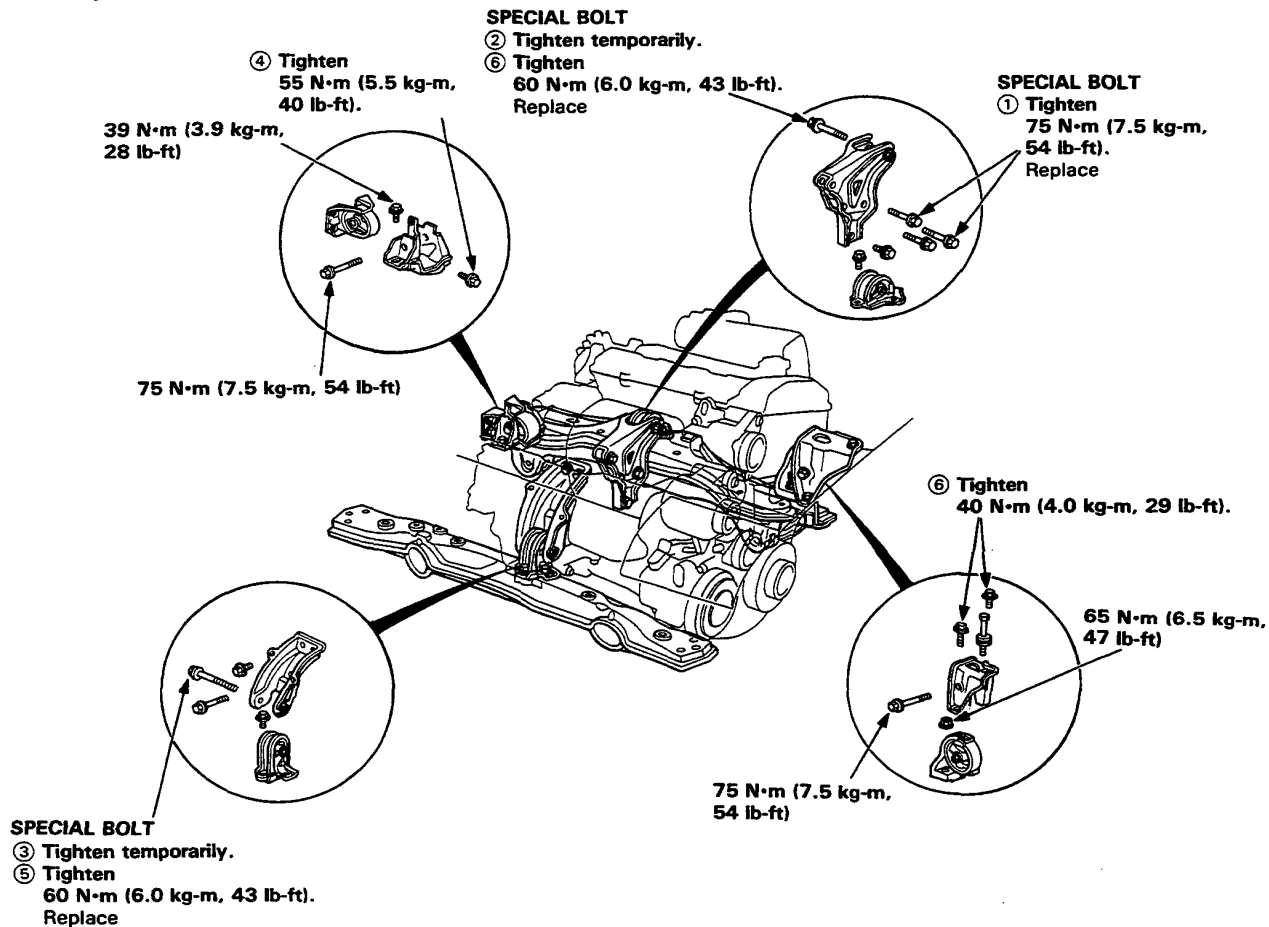

43. Install the engine in the reverse order of removal. After the engine is in place:

- Torque engine mount bolts in sequence shown.

**CAUTION:** Failure to tighten the bolts in the proper sequence can cause excessive noise and vibration, and reduce bushing life; check that the bushings are not twisted or offset.

- Check that the spring clip on the end of each driveshaft clicks into the differential.

**CAUTION:** Use new spring clips on installation.

- Bleed air from the cooling system at the bleed bolt with the heater valve open.

- Adjust the throttle cable tension.
- Adjust the alternator belt and power steering pump belt tension.
- Check the clutch pedal free play.
- Check that the transmission shifts into gear smoothly.
- Install the A/C compressor, connect the wiring and V-belt (with A/C).
- Clean battery posts and cable terminals with sandpaper, assemble, then apply grease to prevent corrosion.

(cont'd)

# Engine Removal/Installation

(cont'd)

NOTE: For proper suppression of noise and vibration, and maximum bushing life, tighten the bolts to the torque mentioned below.

Fuel-Injected Engine Shown; Carbureted Engine similar:

