

Cylinder Head

Installation

1. Install the cylinder head in reverse order of removal:

- Always use a new head gasket.
- Cylinder head and engine block surface must be clean.
- "UP" mark on timing belt pulley should be at the top.

NOTE: Cylinder head dowel pins and oil control jet must be aligned.

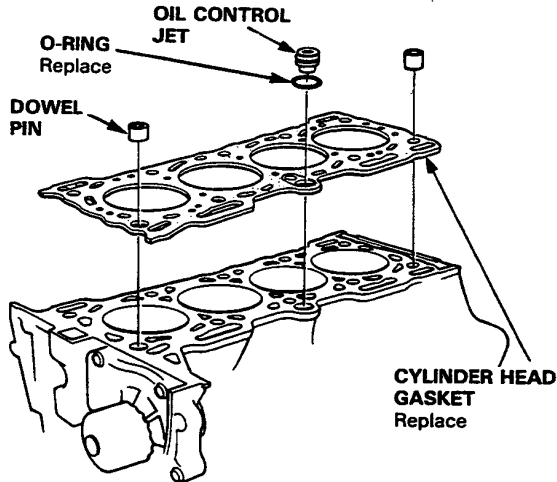

2. Tighten cylinder head bolts in two steps. In the first step tighten all bolts, in sequence, to about 30 N·m (3.0 kg·m, 22 lb-ft); in the final step tighten, in same sequence, to 68 N·m (6.8 kg·m, 49 lb-ft)

NOTE:

- Apply engine oil to the cylinder head bolts and the washers.
- Use the longer bolts at the position No. 1 and No. 2 as shown.

CYLINDER HEAD BOLTS TORQUE SEQUENCE

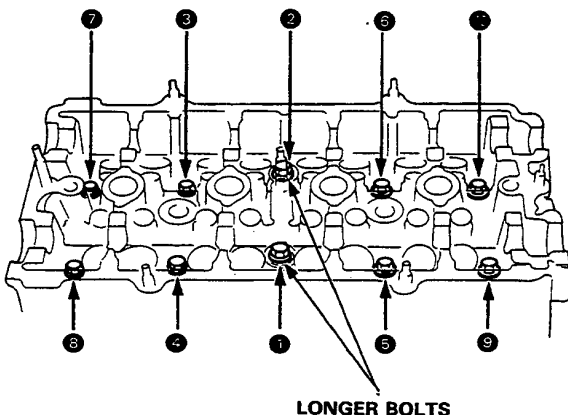

3. Install the intake manifold and tighten the nuts in a criss-cross pattern in 2 or 3 steps, beginning with the inner nuts.

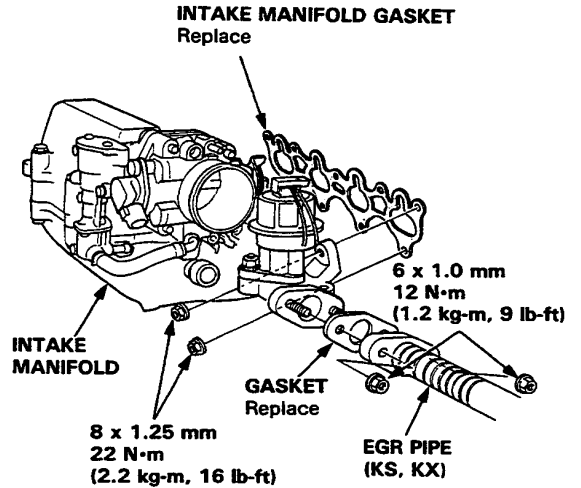

4. Install the exhaust manifold and bracket.

