

Cooling Fan Control

Component Location Index

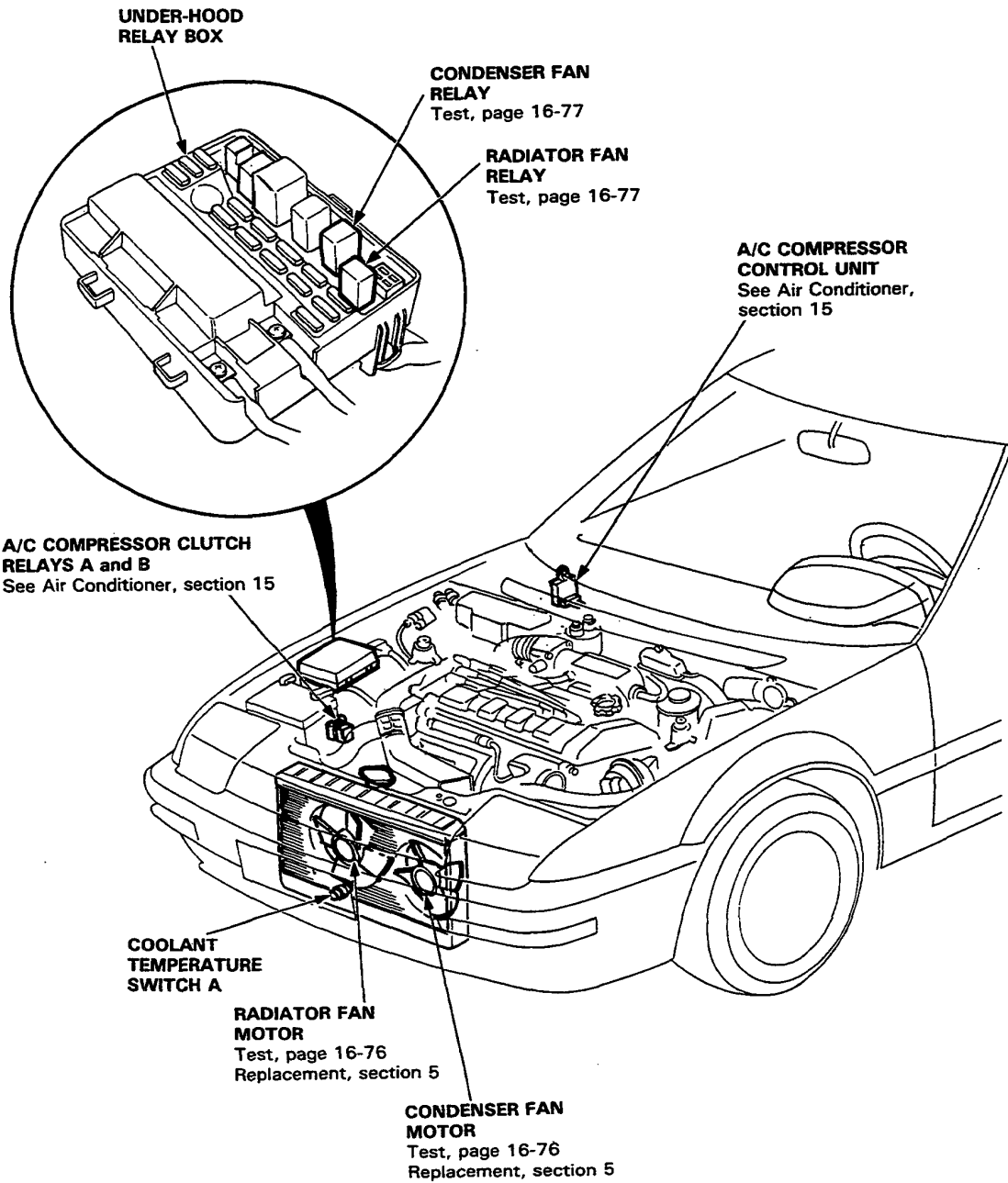



Circuit Diagram

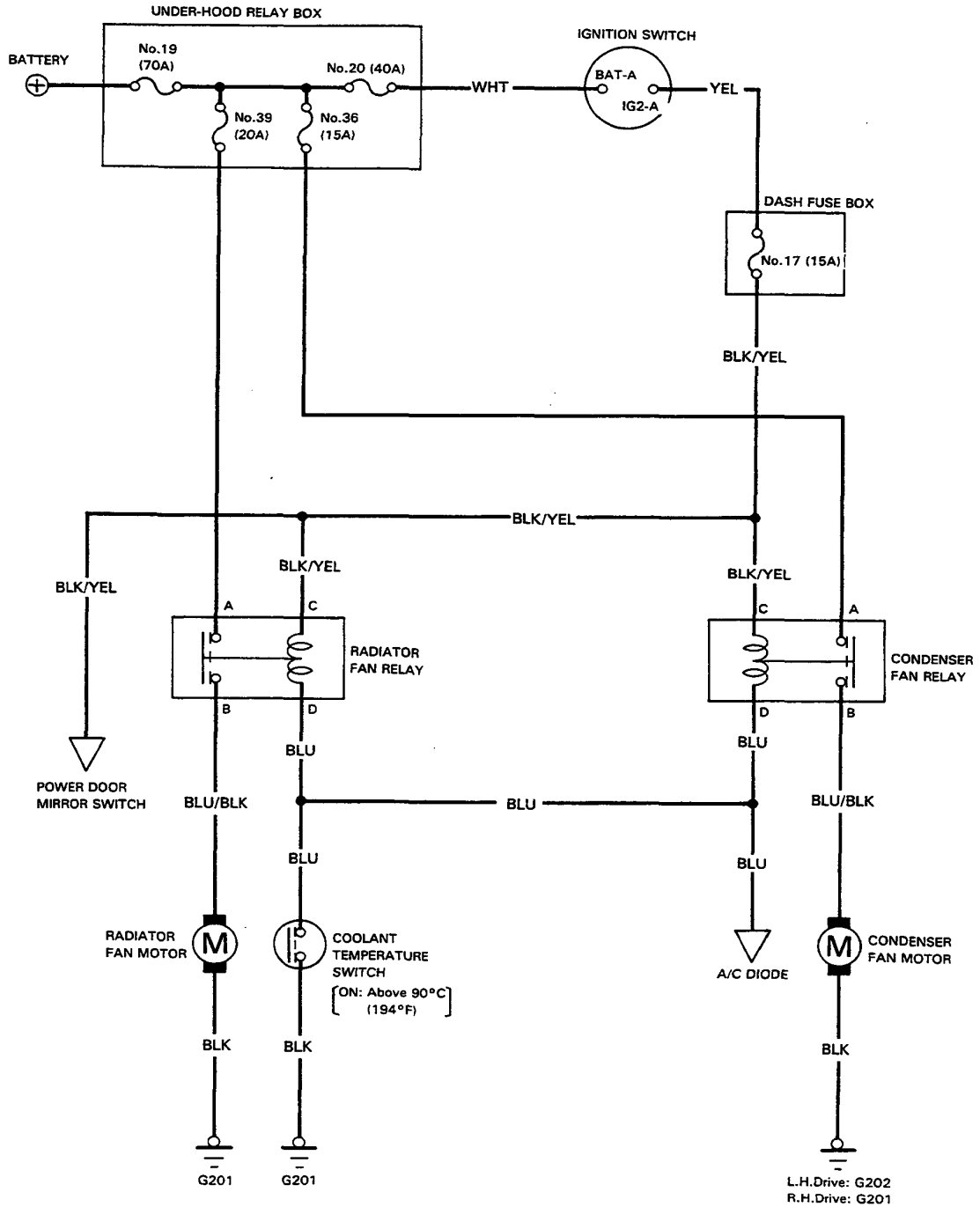

Cooling Fan Control

Fan Motor Test

1. Disconnect the 2-P connector from the fan motor.
2. Test motor operation by connecting battery positive to the A terminal, and negative to the B terminal.
3. If the motor fails to run smoothly, replace it.

Radiator Fan Motor:

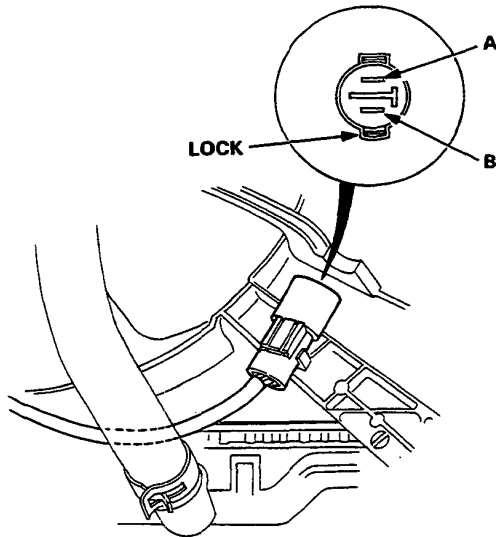

Condenser Fan Motor:

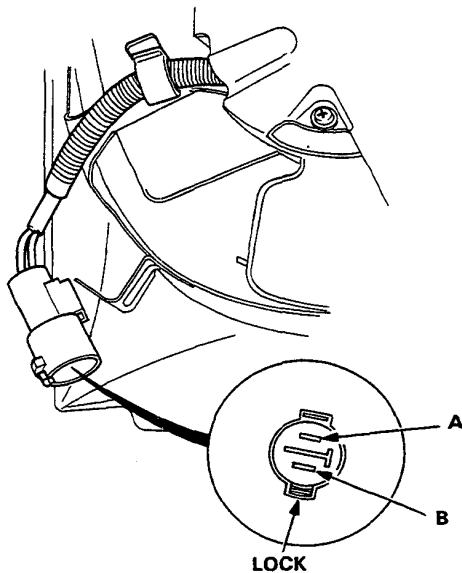

Coolant Temperature Switch Test

1. Remove the coolant temperature switch from the radiator.
2. Suspend the coolant temperature switch in a container of coolant as shown.

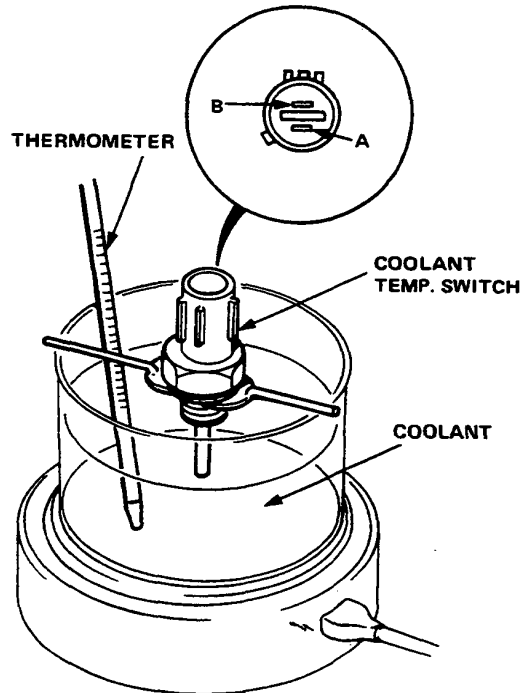

3. Heat the coolant and check coolant temperature with a thermometer.
4. Measure the resistance between the A and B terminals according to the table.

Temperature	Terminal	
	A	B
Above 87–93°C (189–199°F)	○	○
Below 80–91°C (176–196°F)		



Relay Test

1. Remove the radiator or condenser relay in the under-hood relay box.
2. There should be continuity between the A and B terminals when the battery is connected to the C and D terminals.
There should be no continuity when the battery is disconnected.

