

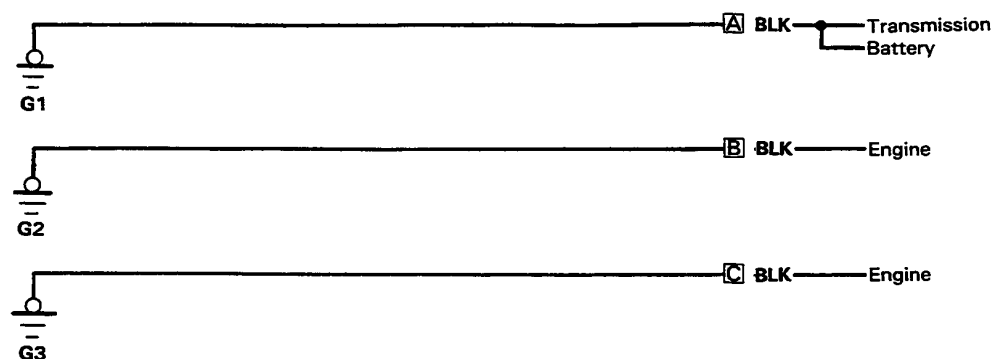

Ground Distribution

Circuit Identification

NOTE: See pages 16-8 and 9 for illustrated ground locations.



L.H. Drive:

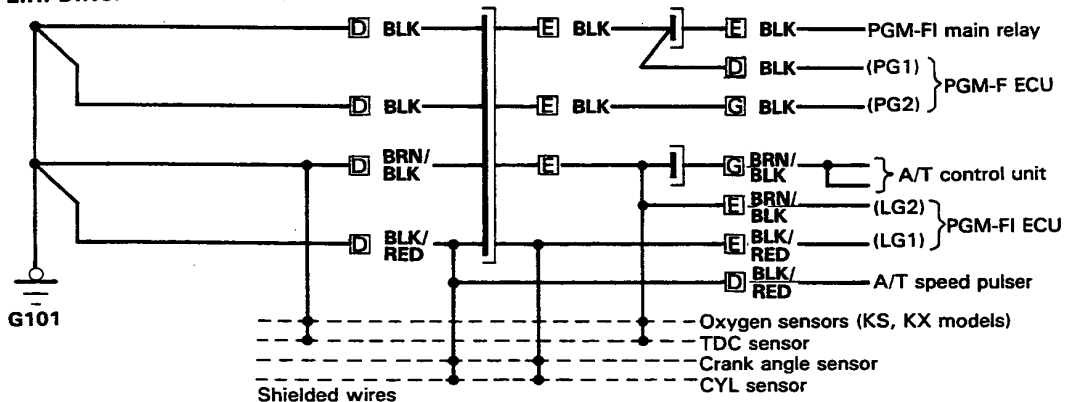

R.H. Drive:

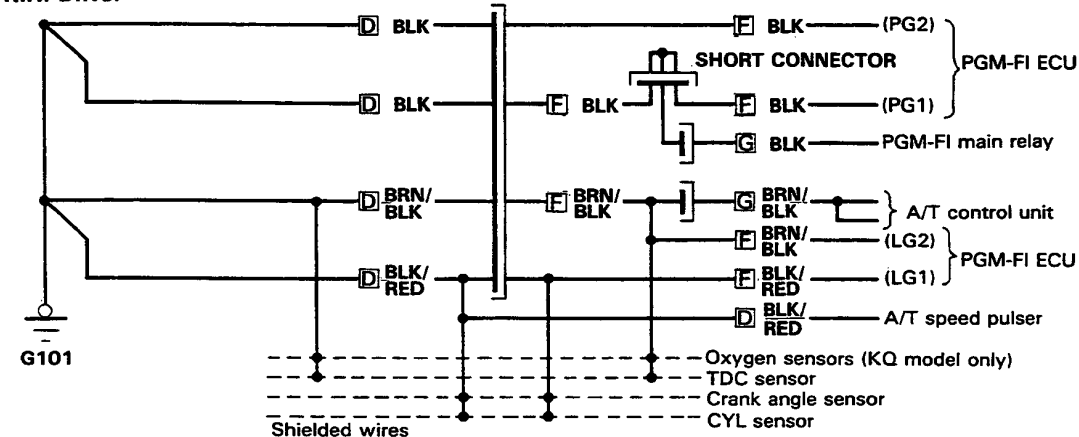

- A**: Battery ground wire
- B**: Engine ground wire A
- C**: Engine ground wire B

- D**: Engine wire harness
- E**: Right engine compartment wire harness
- F**: Left engine compartment wire harness

- G**: Main wire harness

(cont'd)

Ground Distribution

Circuit Identification

NOTE: See pages 16-8 and 10 for illustrated ground locations.

Except KX, KS, KY models:

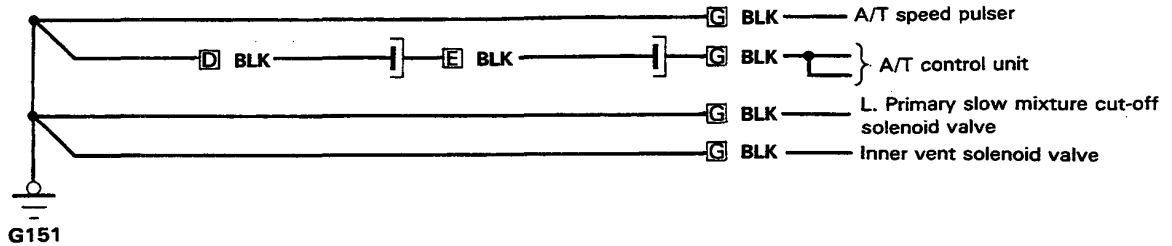

KX, KS, KY models:

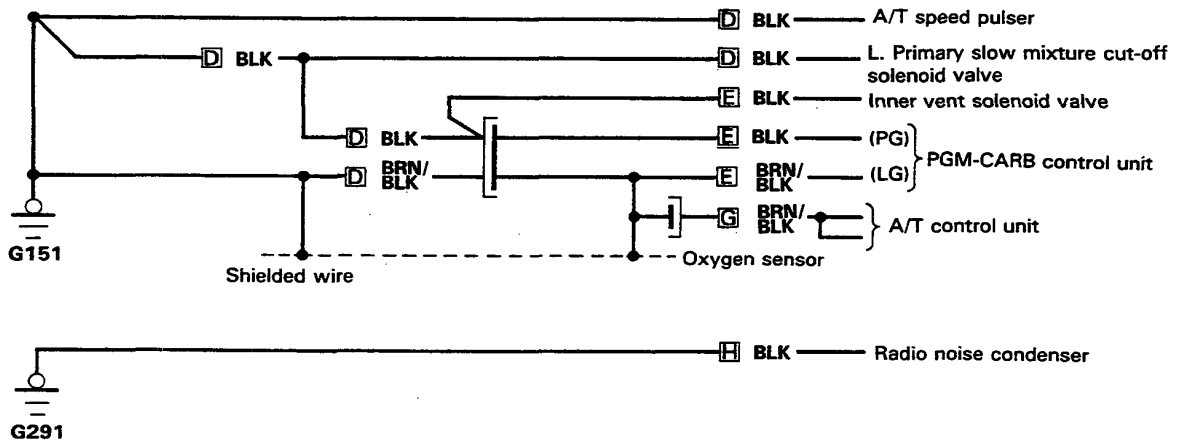

- D: Engine wire harness
- E: Right engine compartment wire harness
- G: Main wire harness
- H: Radio condenser ground wire (On Carbureted engine, this wire is included in the distributor primary lead)



L.H. Drive:

NOTE: See page 16-11 for illustrated ground locations.

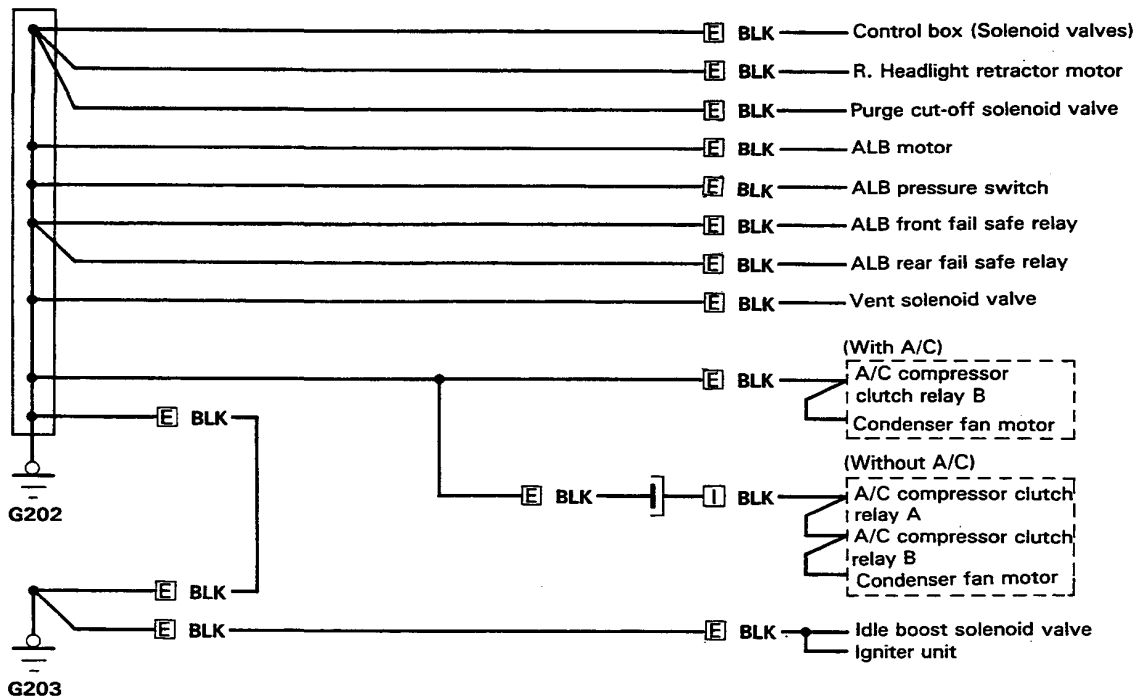
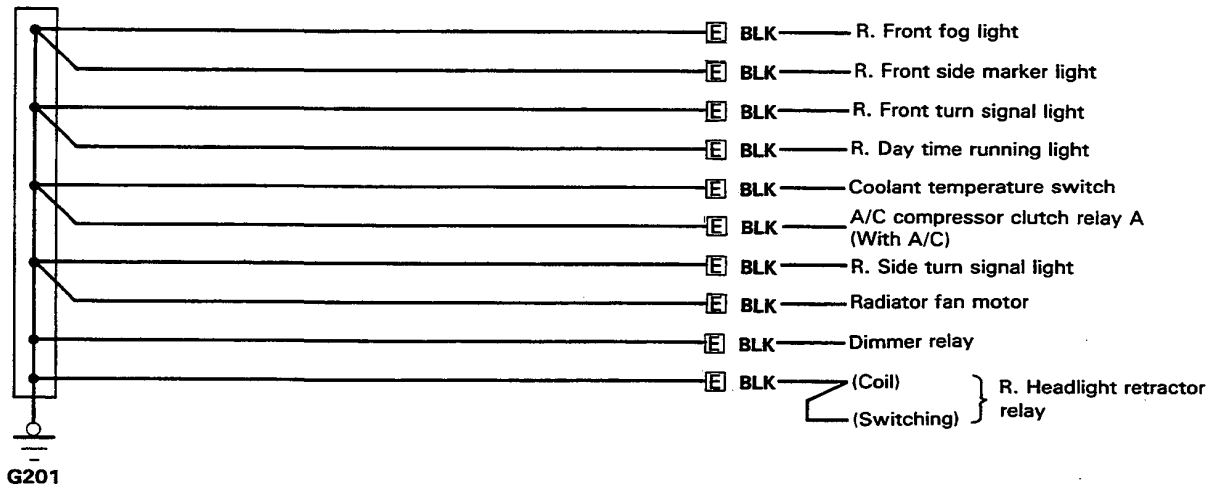

E: Right engine compartment wire harness
 I: A/C wire harness

(cont'd)

Ground Distribution

Circuit Identification (cont'd)

R.H. Drive:

NOTE: See page 16-11 for illustrated ground locations.

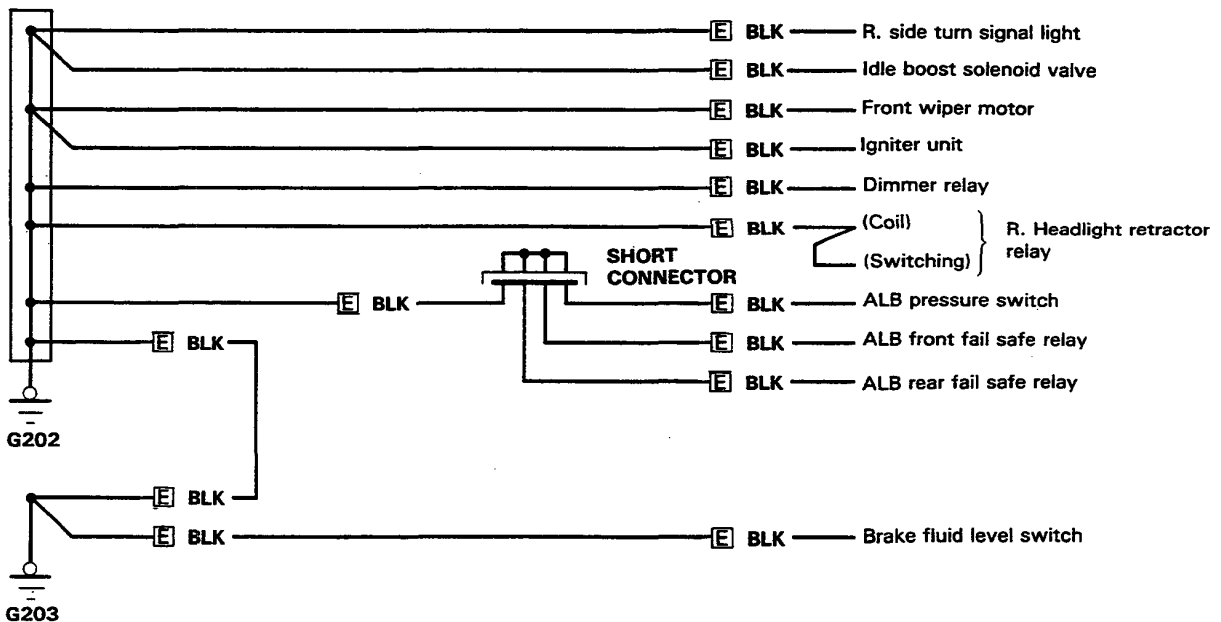
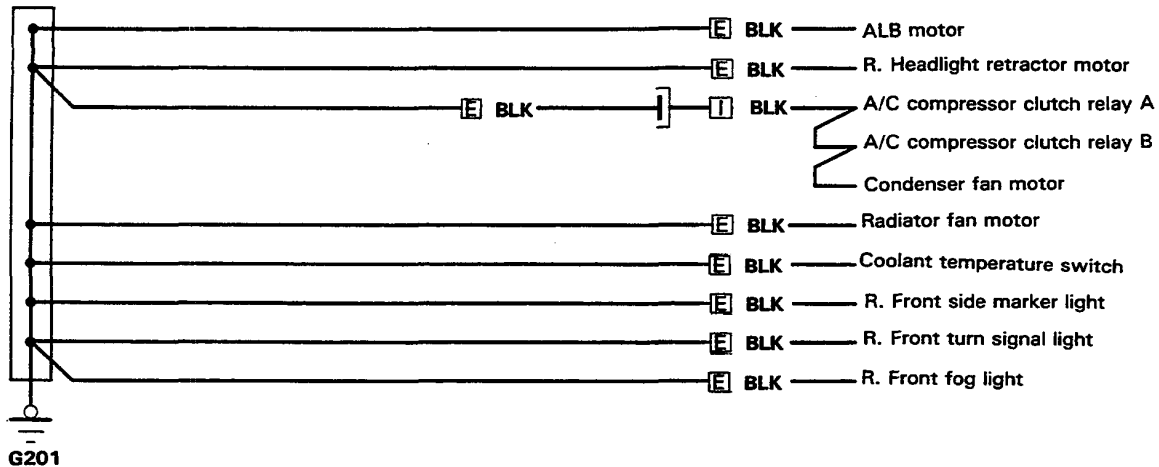

E: Right engine compartment wire harness
I: A/C wire harness



NOTE: See page 16-12 for illustrated ground locations.

L.H. Drive:

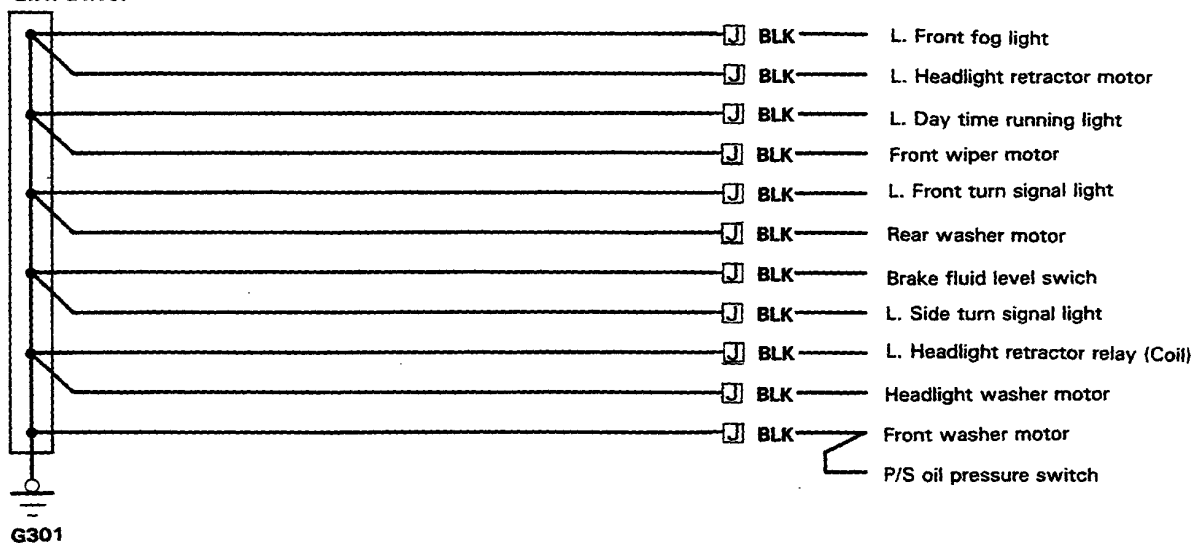

L.H. Drive:

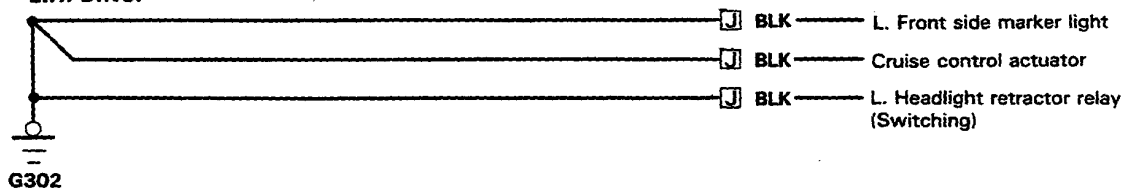

R.H. Drive:

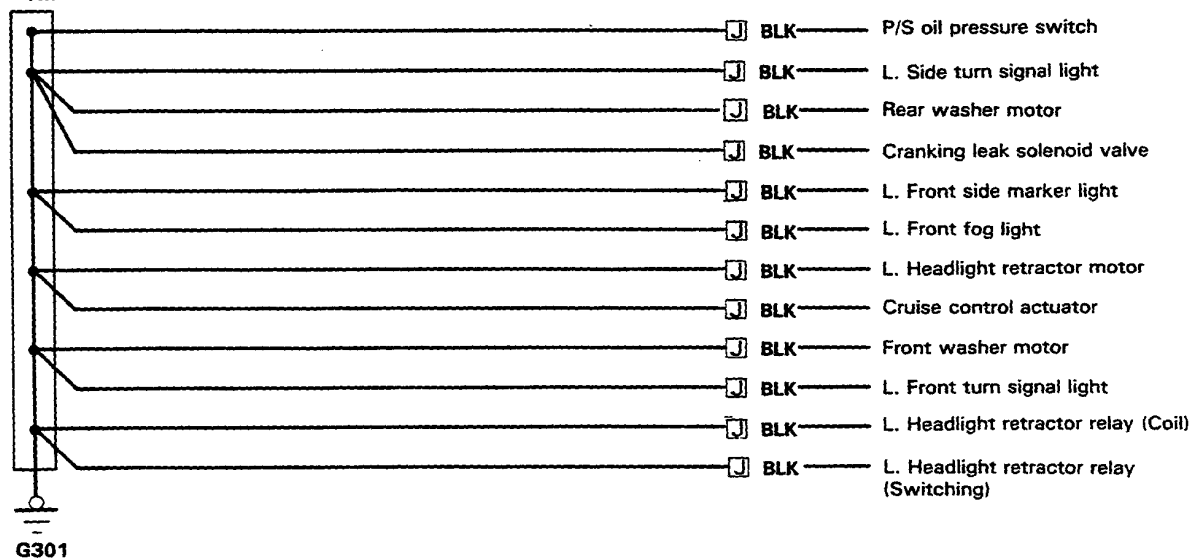

Left engine compartment wire harness

(cont'd)

Ground Distribution

Circuit Identification (cont'd)

L.H. Drive:

NOTE: See pages 16-13 and 14 for illustrated ground locations.

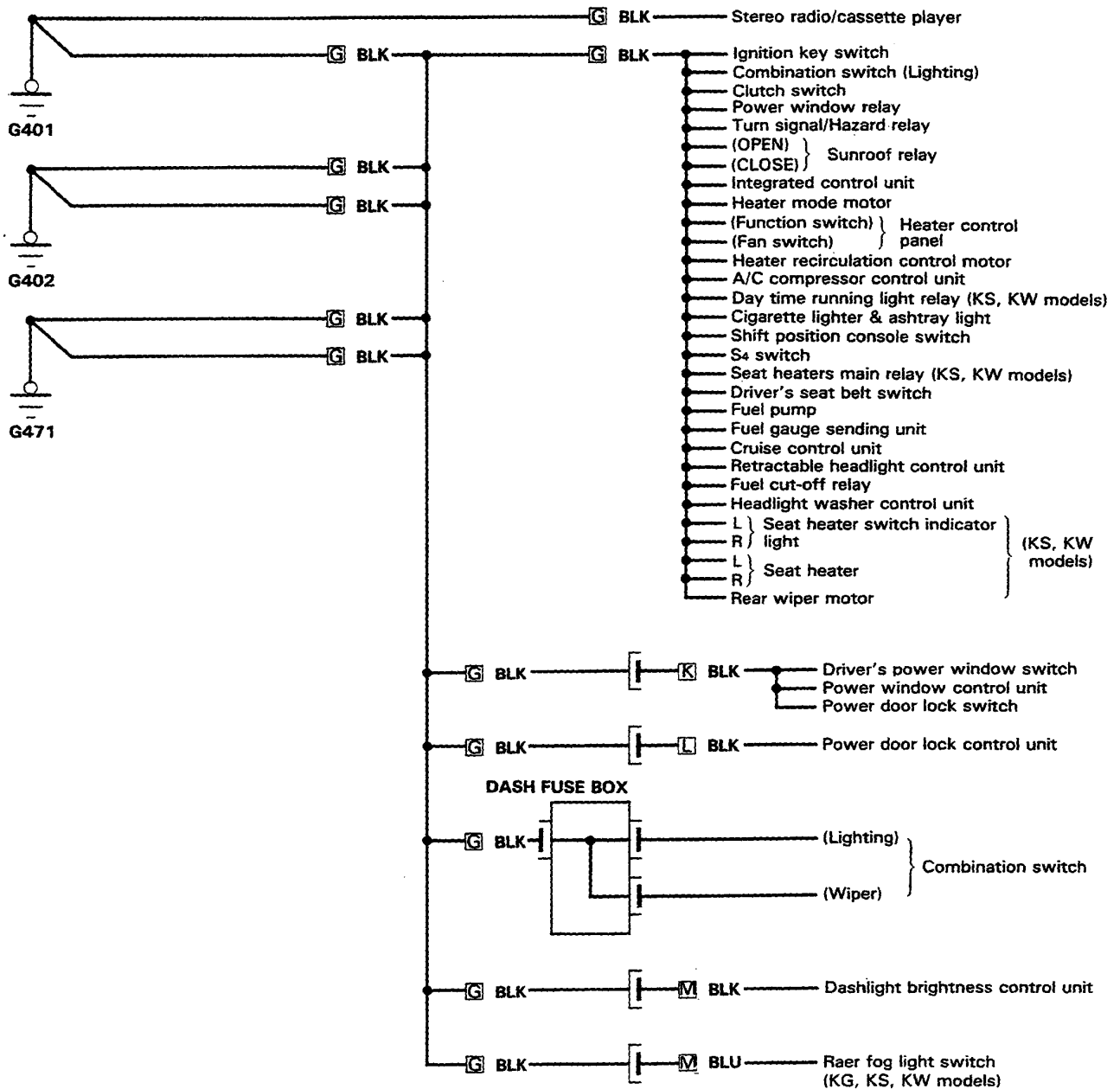

- G**: Main wire harness
- K**: Driver's door wire harness
- L**: Passenger's door wire harness
- M**: Dashboard wire harness



R.H. Drive:

NOTE: See pages 16-13 and 14 for illustrated ground locations.

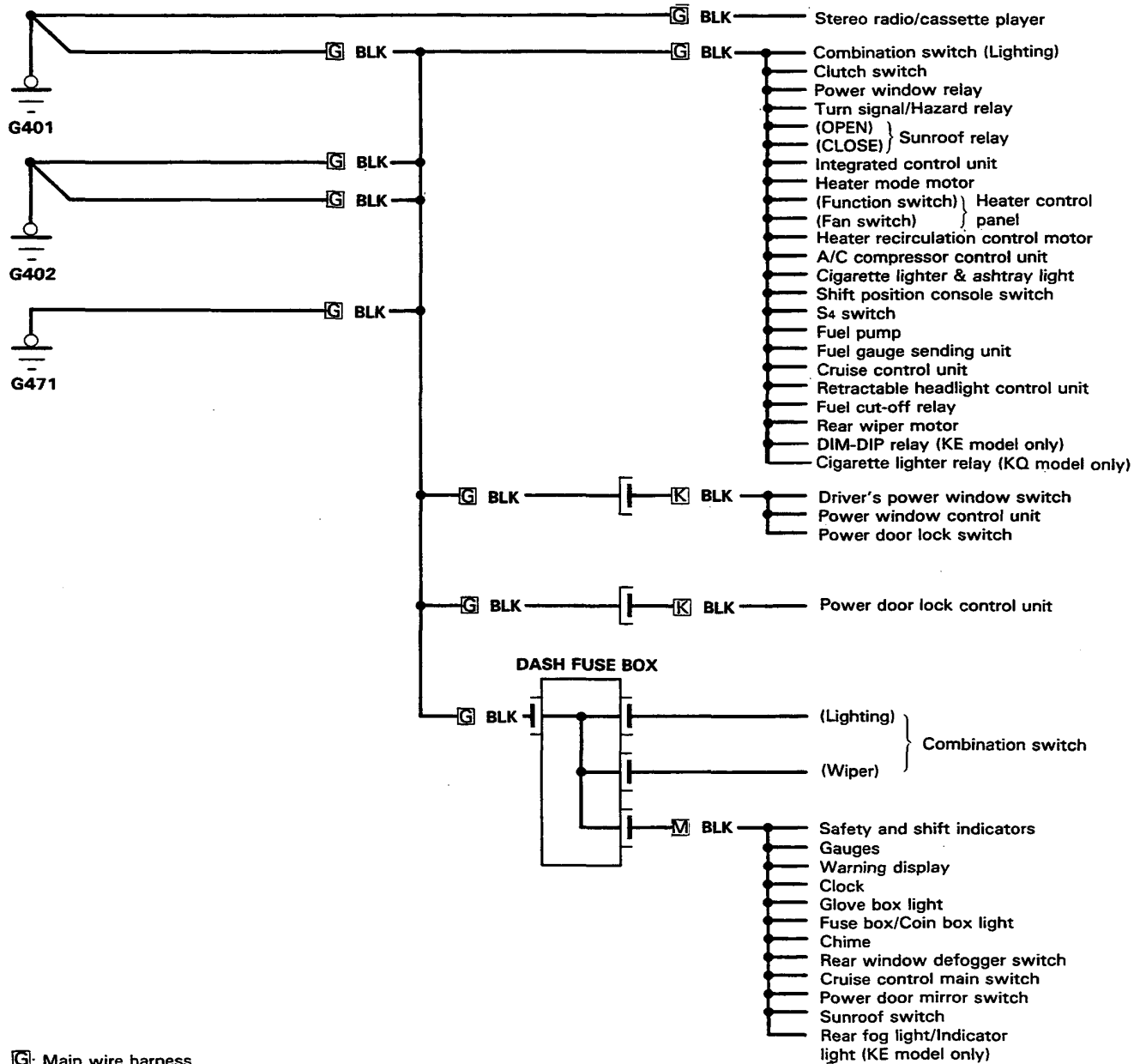

- G**: Main wire harness
- K**: Driver's door wire harness
- L**: Passenger's door wire harness
- M**: Dashboard wire harness

(cont'd)

Ground Distribution

Circuit Identification (cont'd)

NOTE: See pages 16-14 and 16 for illustrated ground locations.

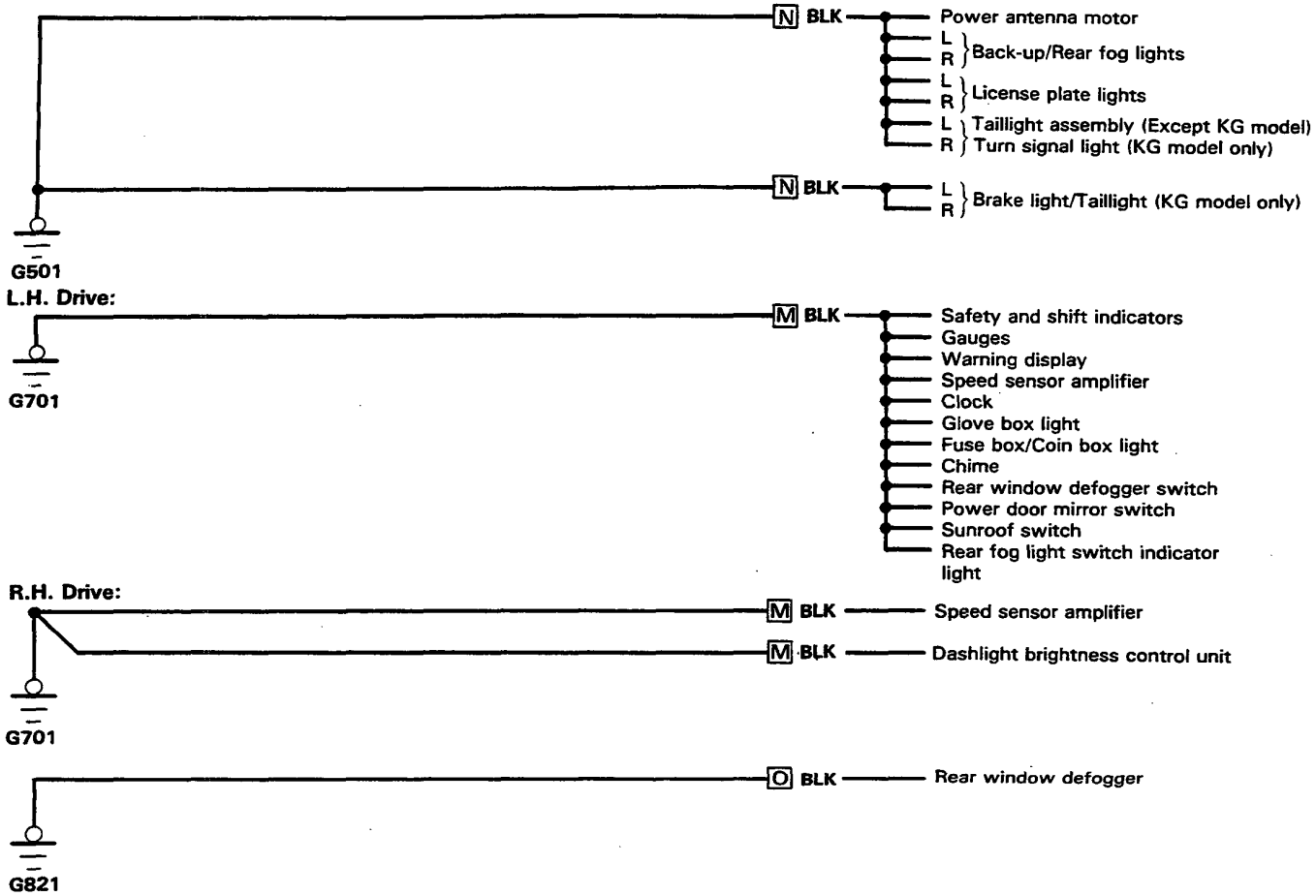

M: Dashboard wire harness
N: Rear wire harness
O: Defogger ground wire