

# Wipers/Washer

## Component Location Index

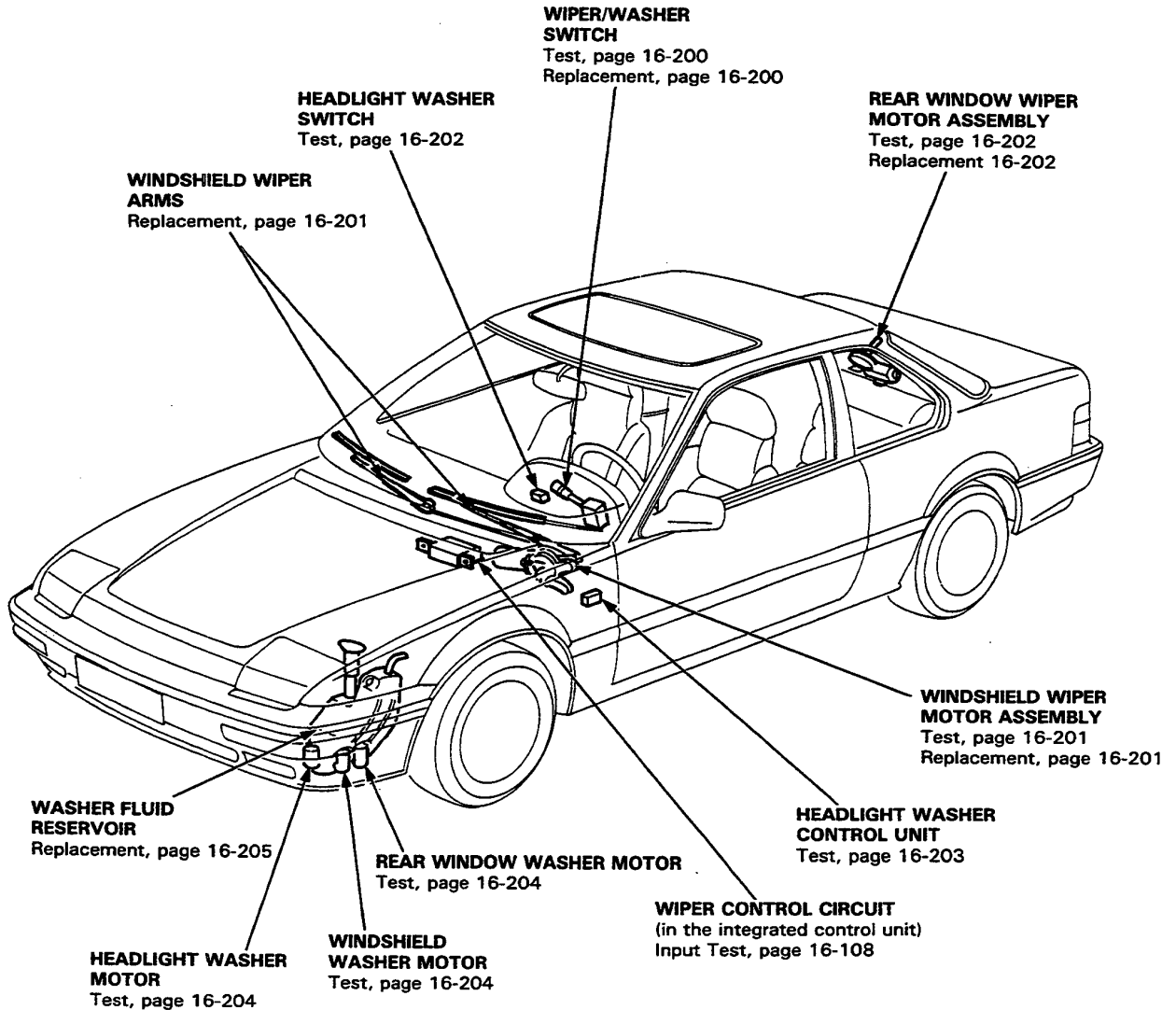



# Circuit Diagram

NOTE: Several different wires have the same color. They have been given a number suffix to distinguish them (for example BLU/WHT<sup>1</sup> and BLU/WHT<sup>2</sup> are not the same).

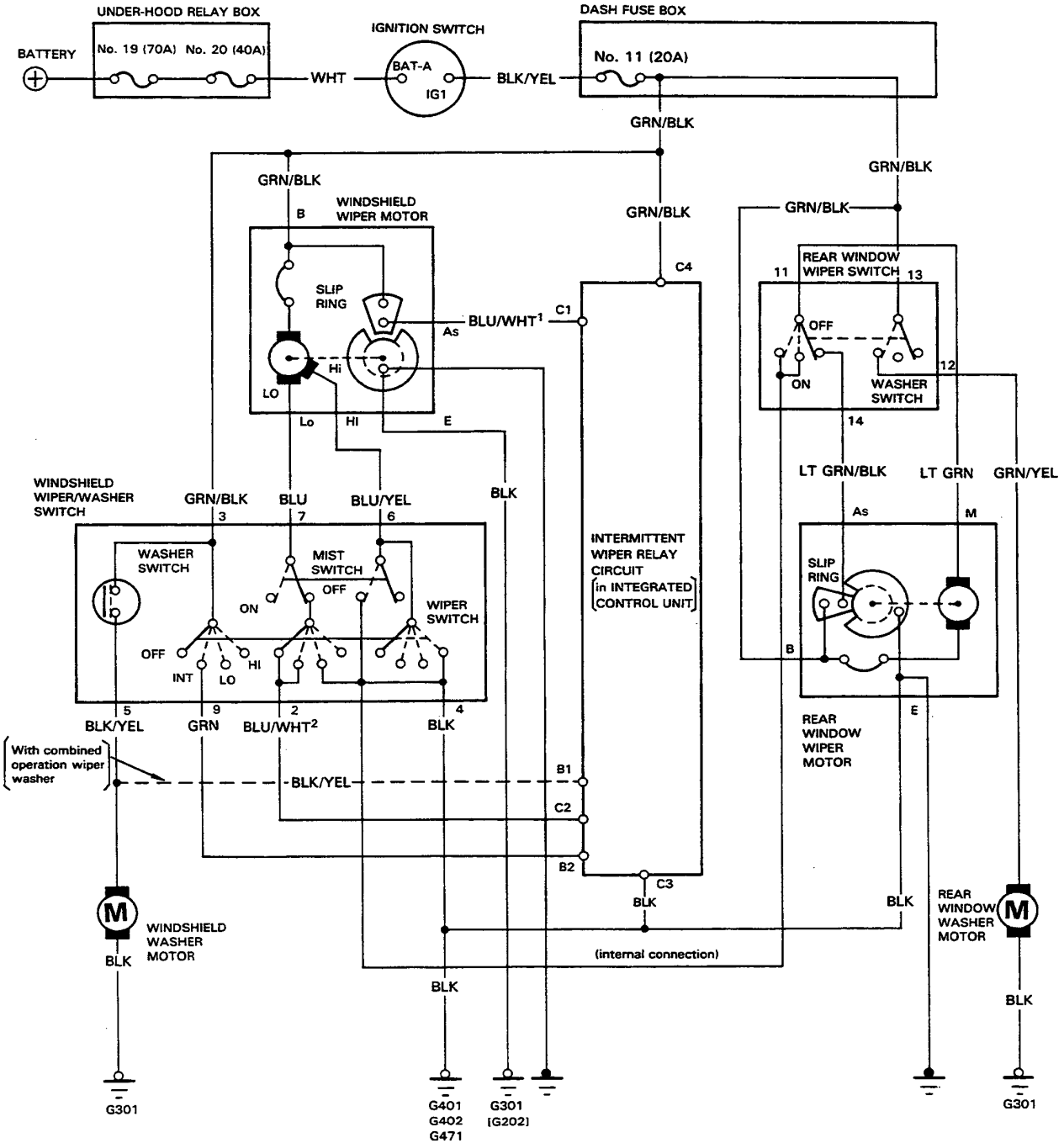

[ ] : R.H. Drive

# Wipers/Washer

## Circuit Diagram (Headlight Washer)

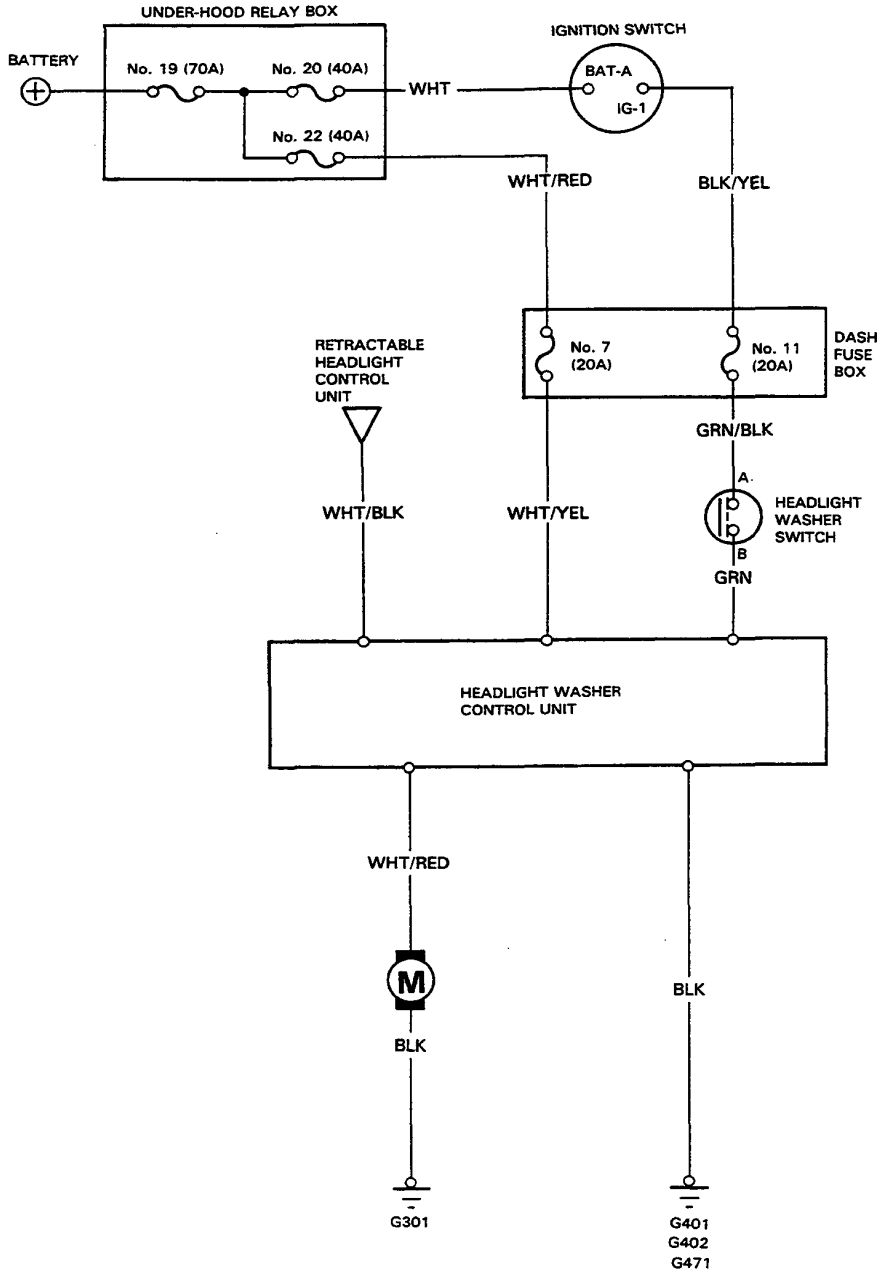



## Troubleshooting

NOTE: The numbers in the table show the troubleshooting sequence.

Item to be inspected		Blown No. 11 (20 A) fuse (in the dash fuse box)	Wiper switch	Wiper motor assembly	Washer switch	Washer motor	Wiper control circuit (in the integrated control unit)	Insufficient washer fluid in reservoir	Disconnected, blocked washer hose or clogged outlet	Disconnected wiper linkages	Poor ground	Open circuit in wires or loose or disconnected terminals
Wipers do not operate.	In all positions.	1	4	2						3	G301 [G202]	GRN/BLK
	In INT.		1			2						GRN, BLU/WHT <sup>2</sup>
	In LO or HI		1									
	In Mist.		1									
Blades do not return to park position when wipers are turned OFF.			2	1								BLU/WHT <sup>1</sup>
Erratic intermittent cycle or wipers do not operate intermittently.			1			2						
Little or no washer fluid is pumped.					4	3		1	2		G301	BLK/YEL
Wipers do not operate simultaneously with washer.							1					BLK/YEL

[ ]: R.H.Drive

# Wipers/Washer

## Wiper/Washer Switch Test

1. Remove the dashboard lower panel to disconnect the 10-P connector and 4-P connector from the dash fuse box.
2. Check for continuity between the terminals in each switch position according to the table.

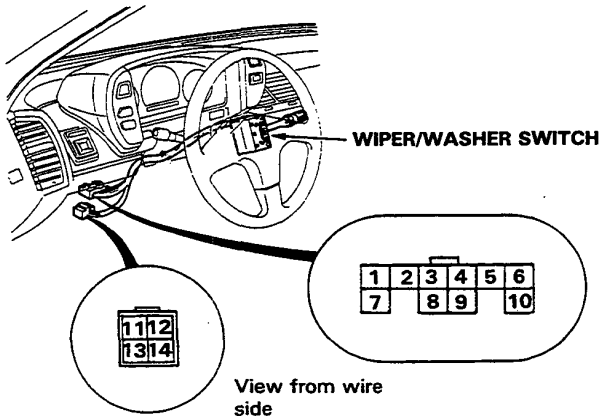

### Windshield Wiper/Washer Switch

Terminal	2	3	4	5	6	7	9
Position							
OFF	○					○	
INT	○	○				○	○
LO			○	○		○	
HI			○	○	○		
Mist Switch "ON"			○	○	○		
Washer Switch "ON"		○	○				

### Rear Window Wiper/Washer Switch

Terminal	4	11	12	13	14
Position					
OFF		○			○
ON	○	○			
Washer Switch "ON"	○	○		○	○

## Wiper/Washer Switch Replacement

1. Remove the dashboard lower panel and disconnect the 10-P connector from the dash fuse box.
2. Remove the lower and upper covers from the steering column.
3. Remove the 2 screws and slide the wiper/washer switch out of the housing as shown.

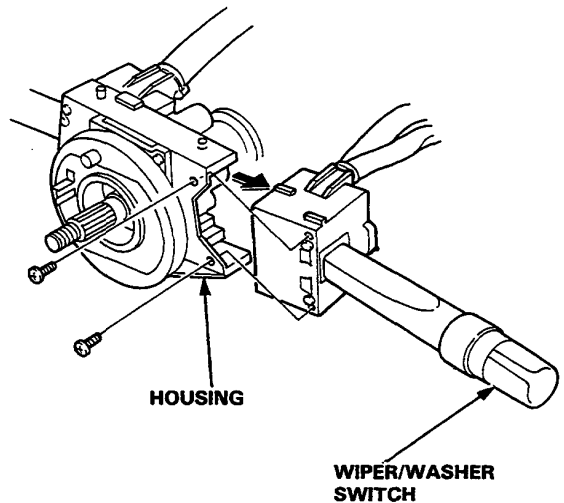



## Windshield Wiper Motor Test

1. Disconnect the 5-P connector of the wiper motor assembly.
2. Test motor operation:  
**LOW SPEED:** Connect battery positive to the B (GRN/BLK) terminal and negative to the Lo (BLU) terminal.  
**HIGH SPEED:** Connect battery positive to the B (GRN/BLK) terminal and negative to the Hi (BLU/YEL) terminal.
3. If the motor fails to run smoothly, replace it.

European and KQ models:

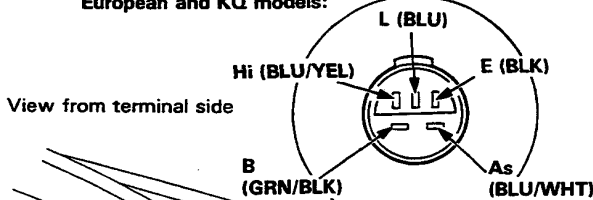

Others:

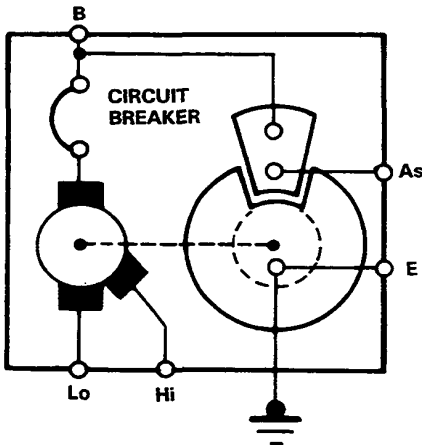
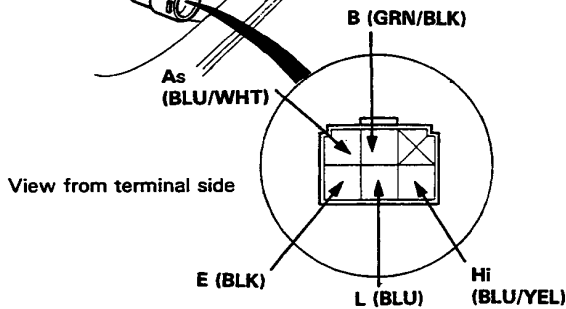

## Windshield Wiper Motor Test

1. Remove the cap nuts and the wiper arms.
2. Remove the hood seal, windshield lower molding and air scoops by prying off the trim clips and removing the screws.

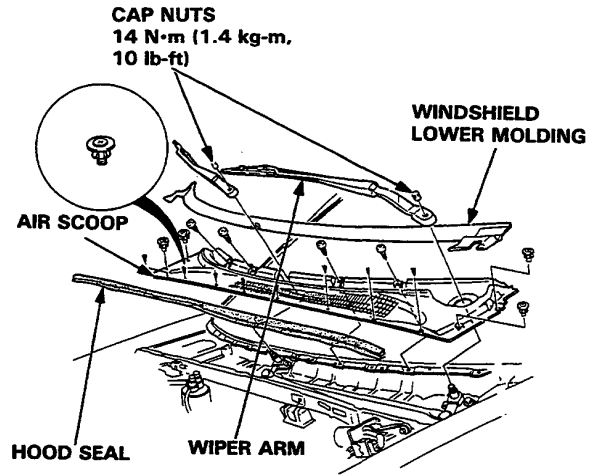

3. Pry the wiper linkage off the motor arm with a screwdriver.
4. Disconnect the 5-P connector from the wiper motor assembly, then remove the 4 mount bolts and the wiper motor assembly.

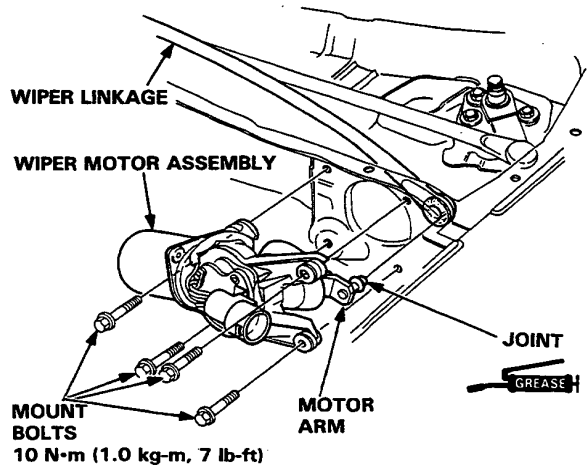

5. Install the wiper motor assembly in the reverse order of removal.

# Wiper/Washer

## Rear Window Wiper Motor Test

1. Open the trunk lid and disconnect the 4-P connector.
2. Test motor operation by connecting battery positive wire to B terminal and negative M terminal.
3. If the motor fails to run smoothly, replace it.

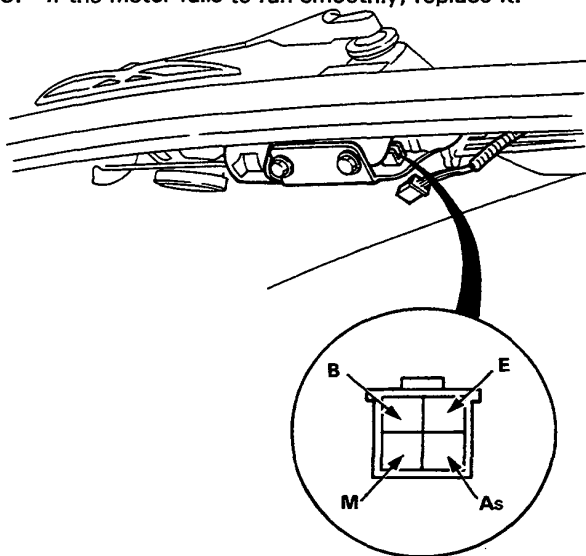

4. Check for continuity between the terminals according to the table.

Terminal	B	As	E
Wiper Blade			
At park position	○—○		
At center position		○—○	

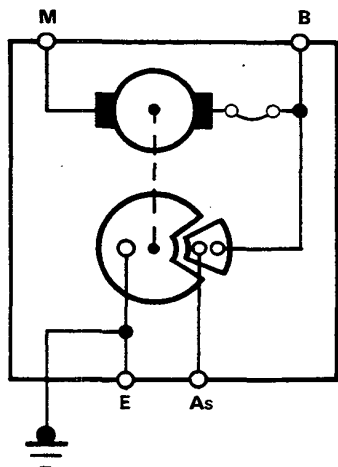

## Rear Window Wiper Motor Replacement

1. Open the trunk lid and disconnect the 4-P connector.
2. Remove the trim cover, 6 mm nut, wiper arm, pivot cap, special nut/washer and the outside seal rubber.
3. Remove the 3 mount bolts and the wiper motor.

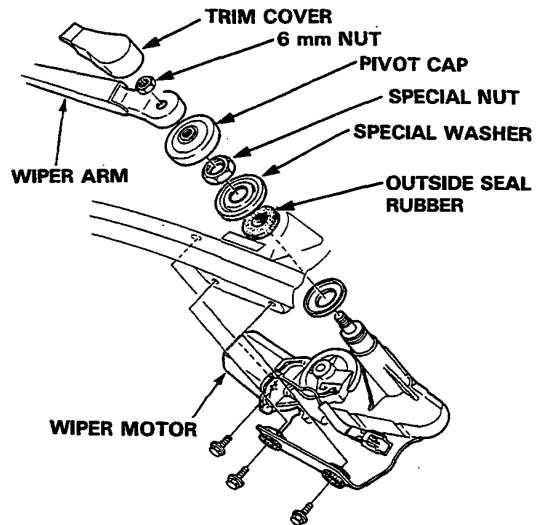

## Headlight Washer Switch Test

1. Remove the switch from the instrument panel.
2. Check for continuity between the terminals according to the table.

Terminal Position	A	B
OFF		
ON	○—○	○—○

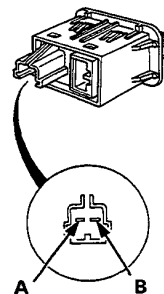



## Headlight Washer Control Unit Test

Remove the dashboard lower panel to disconnect the 6-P connector from the control unit.

Make the following input tests at the harness pins.

If all tests prove OK, yet the headlight washer still fails to work, replace the control unit.

**NOTE:** Before testing, check the No. 7 (20 A) and No. 11 (20 A) fuses in the dash fuse box.

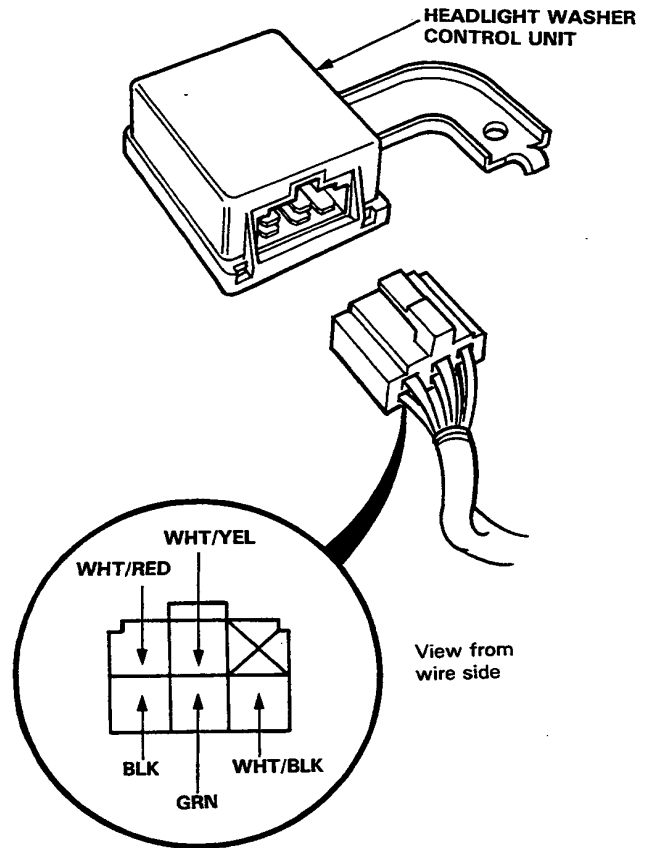

No.	Wire	Test condition	Test: desired result	Possible cause (if result is not obtained)
1	BLK	Under all conditions.	Check for continuity to ground: should be continuity.	<ul style="list-style-type: none"> <li>• Poor ground (G401, G402, G471).</li> <li>• An open in the wire.</li> </ul>
2	WHT/YEL	Under all conditions.	Check for voltage to ground: should be battery voltage.	<ul style="list-style-type: none"> <li>• Blown No. 7 (20 A) fuse.</li> <li>• An open in the wire.</li> </ul>
3	GRN	Ignition switch and headlight washer switch ON.	Check for voltage to ground: should be battery voltage.	<ul style="list-style-type: none"> <li>• Blown No. 11 (20 A) fuse.</li> <li>• Faulty headlight washer switch.</li> <li>• An open in the wire.</li> </ul>
4	WHT/RED	Connect the WHT/YEL terminal to the WHT/RED terminal with jumper wire.	Check pump operation: Pump should run.	<ul style="list-style-type: none"> <li>• Faulty headlight washer pump.</li> <li>• An open in the wire.</li> <li>• Poor ground (G301).</li> </ul>
5	WHT/BLK	Headlight ON.	Check for voltage to ground: should be battery voltage.	<ul style="list-style-type: none"> <li>• An open in the wire.</li> <li>• Faulty retractable headlight control unit.</li> </ul>

# Wipers/Washers

## Washer Motor Test

1. Remove the front bumper and disconnect the 2-P connectors from the washer motors.
2. Test motor operation by connecting battery positive wire to the  $\oplus$  terminal and negative to the  $\ominus$  terminal.
3. If the motor fails to run, replace it.

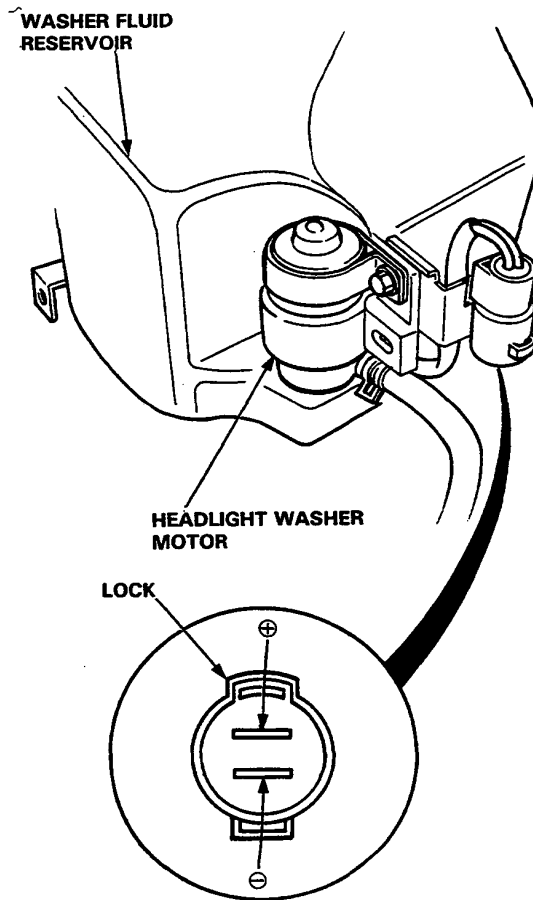
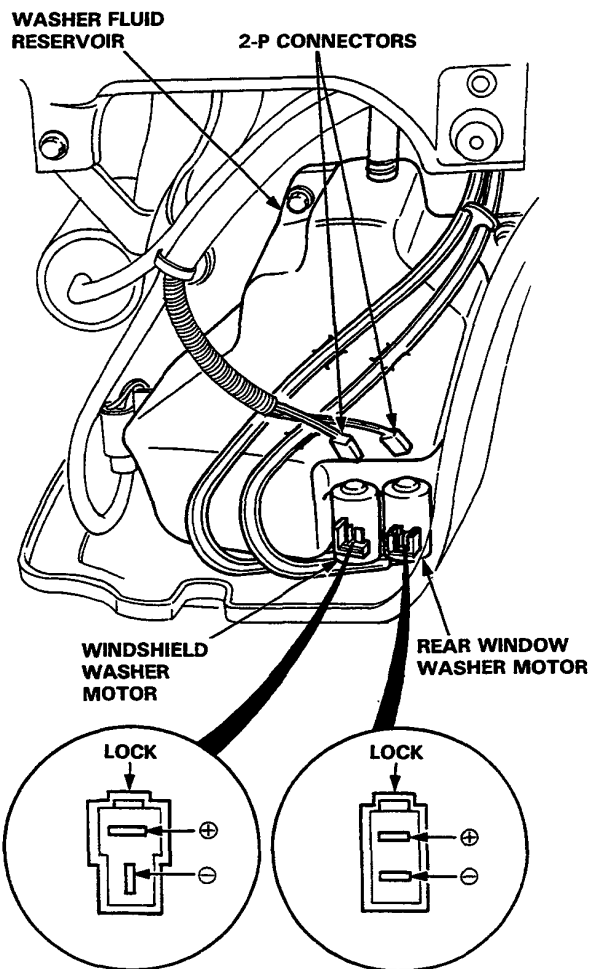

- If the motor fails to run smoothly, replace it.
- If the motor runs smoothly and little or no washer fluid is pumped, check for disconnected, blocked washer hose or clogged outlet and faulty pump in the motor.



## Washer Replacement

1. Remove the bumper, then remove the washer reservoir by removing the 3 mount bolts.
2. Disconnect the hose and the 2-P connector from the washer motor.
3. Remove the deflector which has washer nozzles by removing the 2 screws and prying off the trim clips.
4. Remove the headliner then remove the rear washer nozzle by releasing the retaining pawl and pushing them out from the underside of the roof.
5. Remove the headlight washer nozzle by releasing the retaining pawl and pushing them out from the inside of the bumper.
6. Install the washer in the reverse order of removal.

### NOTE:

- Clamp the hoses with the wire harness in the left front fender.
- Take care not to pinch hoses during reinstallation.
- Install the grommets firmly.
- After installation, adjust the washer nozzles.

