

Power Distribution

Circuit Identification

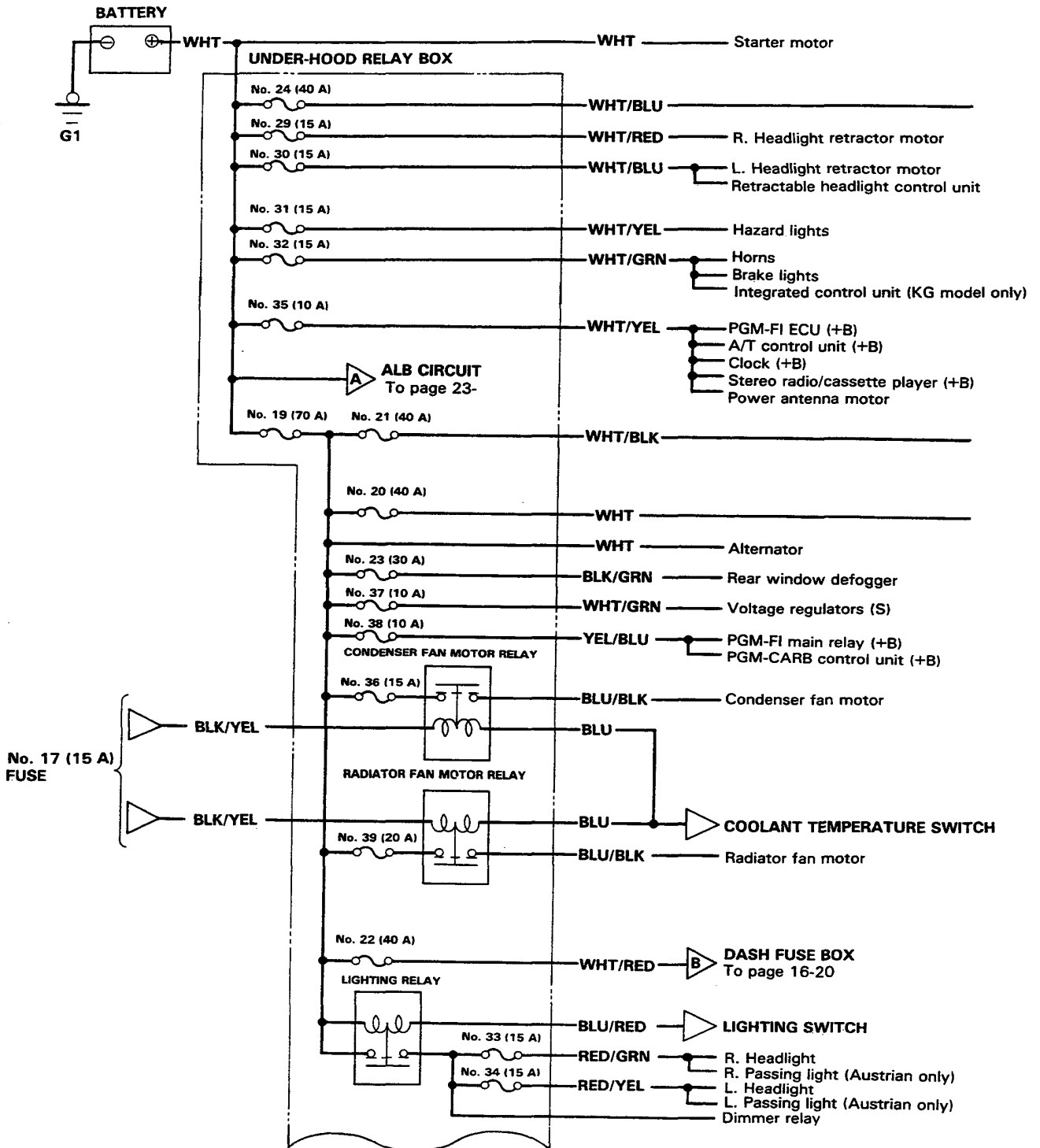

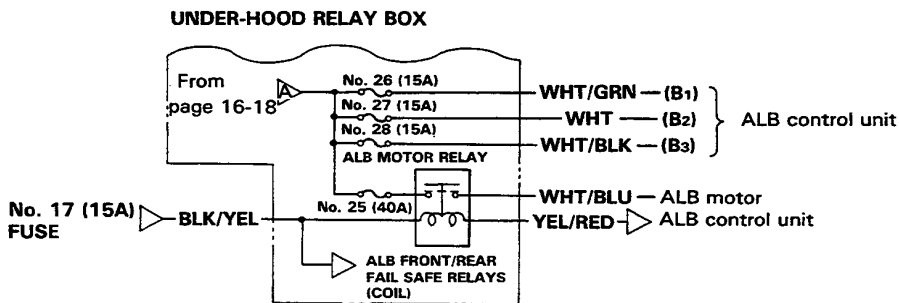
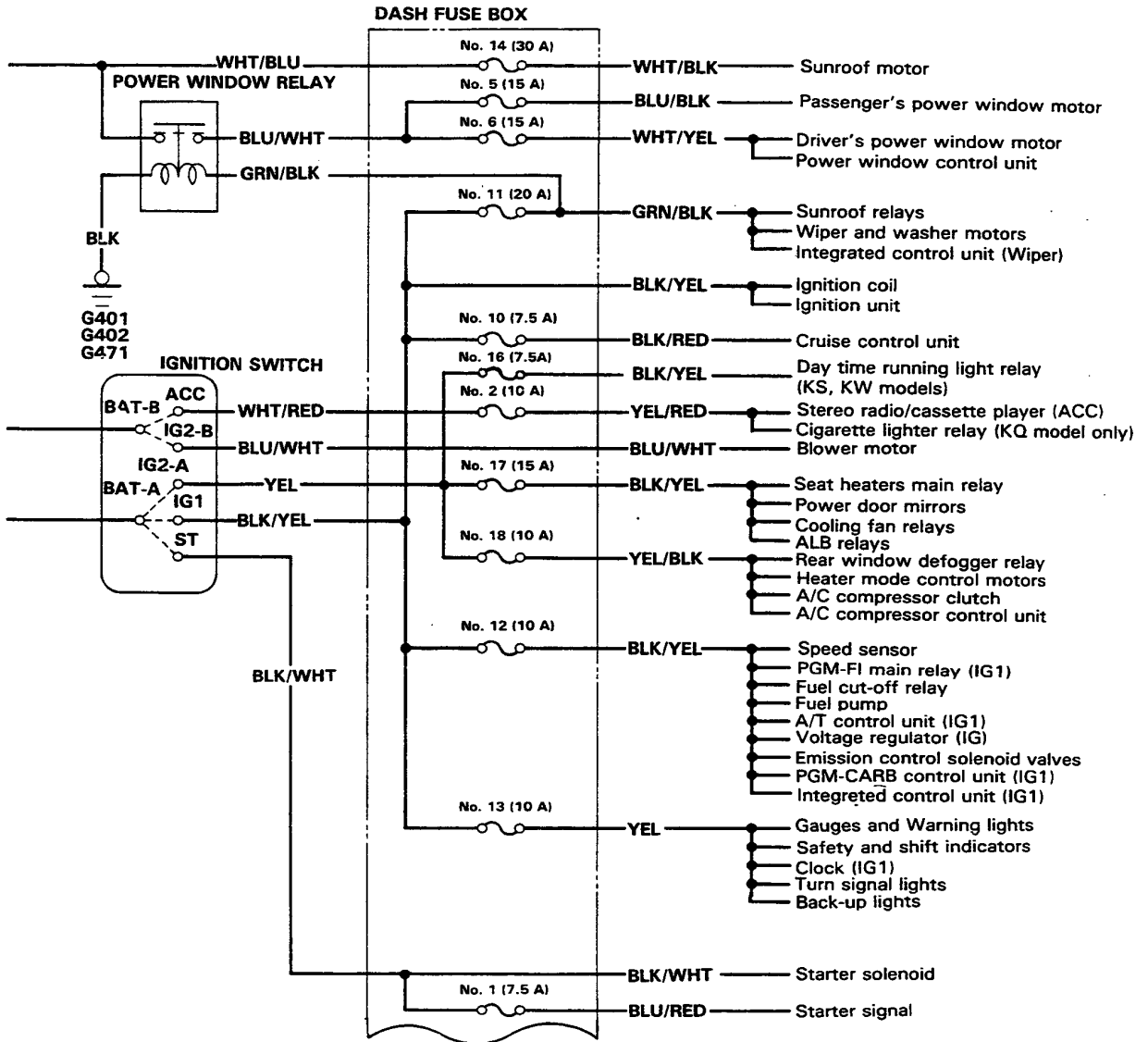

(cont'd)

Power Distribution

Circuit Identification (cont'd)

<KG, KB, KX, KF, KE>

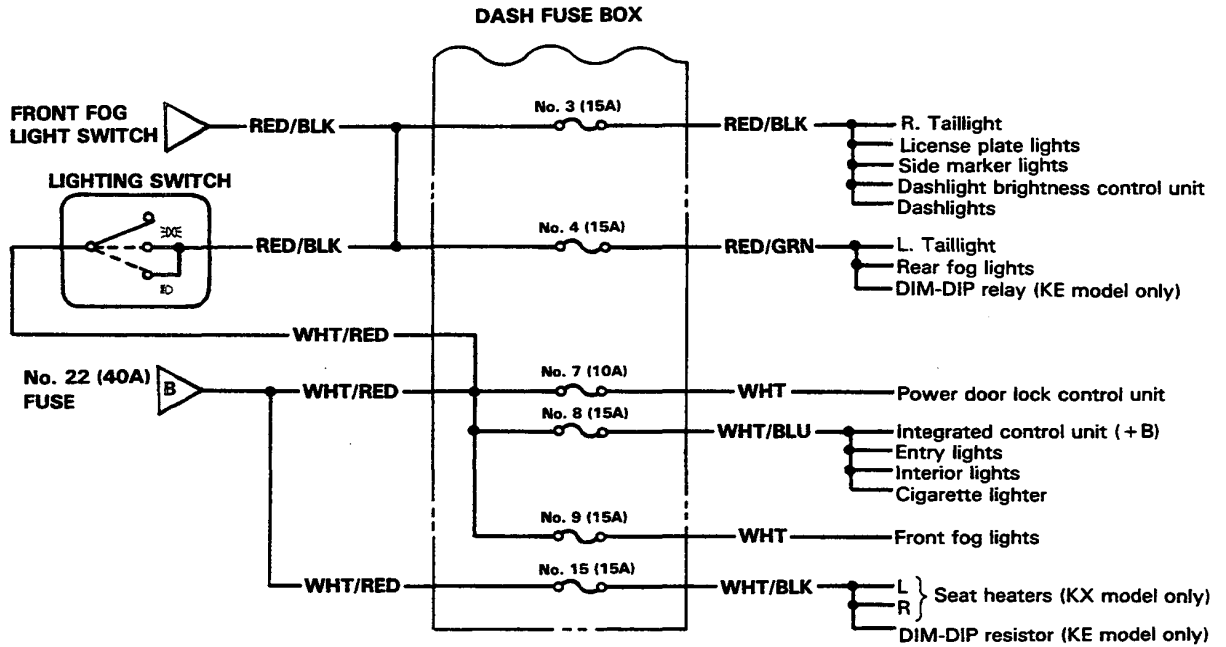

<KS, KW, KQ, KT, KY>

