

# Rear Window Defogger

## Component Location Index

**DEFOGGER SWITCH**  
Removal, page 16-85  
Test, page 16-172

**REAR WINDOW DEFOGGER**  
Function Test, page 16-171  
Defogger Wire Repair, page 16-171

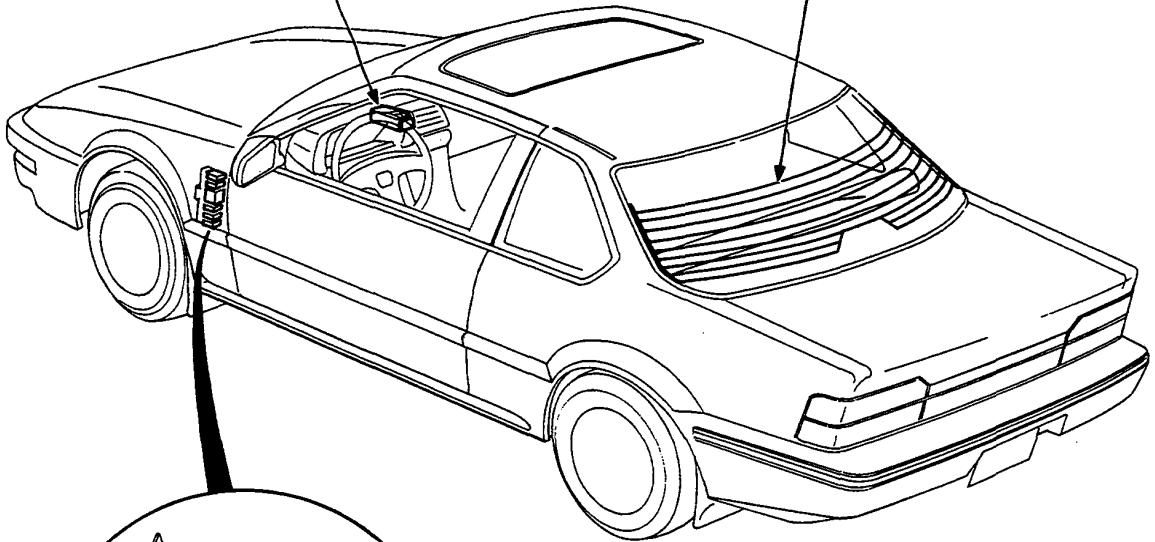

**DEFOGGER RELAY**  
Test, page 16-172

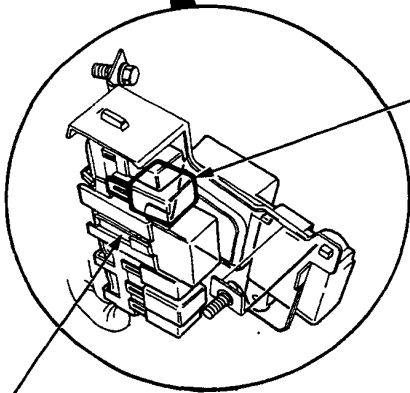

**DASH RELAY HOLDER**  
(Located under dash, left side)



# Circuit Diagram

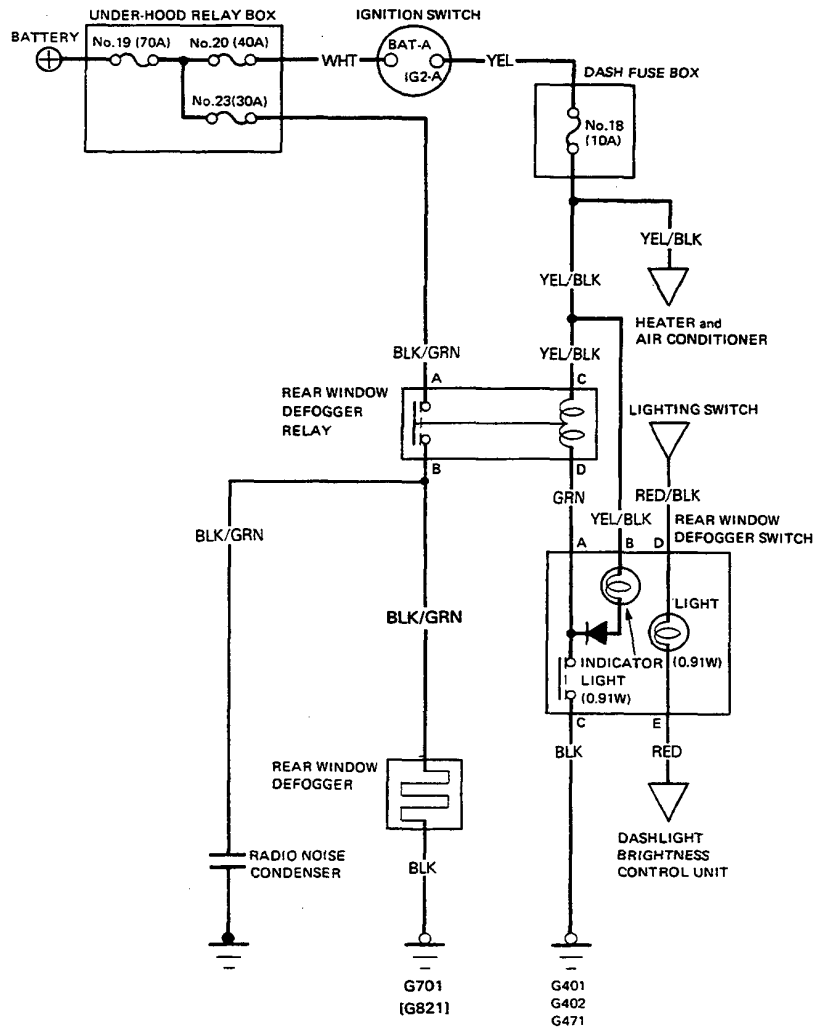

[ ]: R.H. Drive

# Rear Window Defogger

## Troubleshooting

NOTE: The numbers in the table show the troubleshooting sequence.

Symptom	Item to be inspected							Poor ground	Open circuit in wires or loose or disconnected terminals
	Blown indicator light bulb	Blown No. 18 (10 A) fuse (in the dash fuse box)	Blown No. 23 (30 A) fuse (in the under-hood relay box)	Defogger switch	Function test	Defogger relay	Repair defogger wire		
Defogger operates, but indicator light does not go on.	1								
Defogger does not operate and indicator light does not go on.		1		2	3			G401, G402 G471, G701 [G821]	YEL/BLK or GRN
Defogger does not operate, but indicator light goes on.			1		2	3		G701 [G821]	BLK/GRN or GRN
Broken defogger wire							1		

[ ]: R.H.Drive

# Rear Window Defogger



## Function Test

**CAUTION:** Be careful not to scratch or damage the defogger wires with the tester probe end.

1. Check for voltage between the positive terminal and body ground with the ignition switch and the defogger switch ON.  
There should be battery voltage.
  - If there is no voltage, check for:
    - Faulty defogger relay.
    - An open in the BLK/GRN or GRN wire.
  - If there is battery voltage, go to step 2.

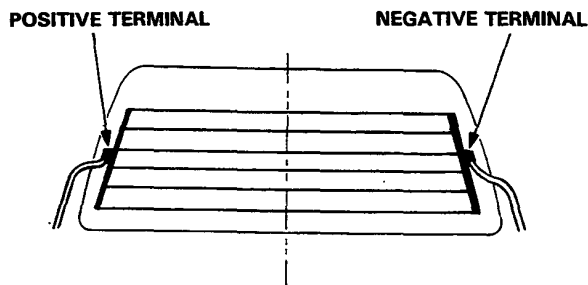

2. Check for continuity between the negative terminal and body ground.  
If no continuity, check for open in the defogger ground wire.
3. Lightly touch the voltmeter positive probe to the center of each defogger wire, and negative probe to the negative terminal.  
There should be approximately with the ignition switch and defogger switch ON.
  - If the voltage is as specified, the defogger wire is OK.
  - If there is battery voltage, the defogger wire is broken in the negative side of the center.
  - If there is no voltage the defogger wire is broken in the positive side of the center.

## Defogger Wire Repair

**NOTE:** Repair section must be no longer than one inch.

1. Lightly rub area around the break with fine steel wool, then clean with alcohol.
2. Carefully mask above and below the broken portion of the defogger wire with cellophane tape.

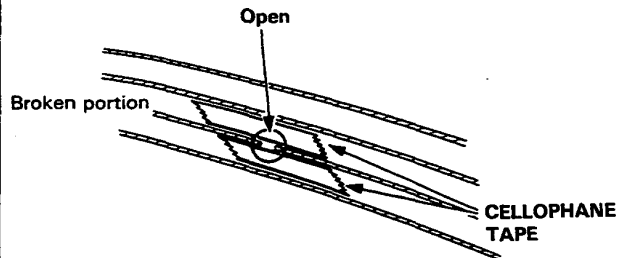

3. Using a small brush, apply heavy coat of silver conductive paint extending about 1/8 in. on both sides of the break. Allow 30 minutes to dry.

**NOTE:** Thoroughly mix paint before use.

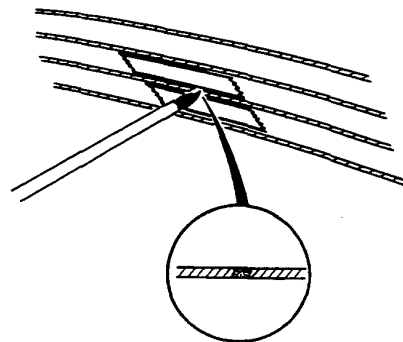

4. Check for proper operation with a voltmeter (approximately at the mid-point).
5. Apply a second coat of paint in the same manner. Dry 3 hours before removing tape.

## Switch Test

NOTE: For the switch removal, see page 16-85.

1. Remove the instrument panel from the dashboard.
2. Check for continuity between the terminals according to the table.

Terminal Position	A	B		C	D		E
ON							
OFF							

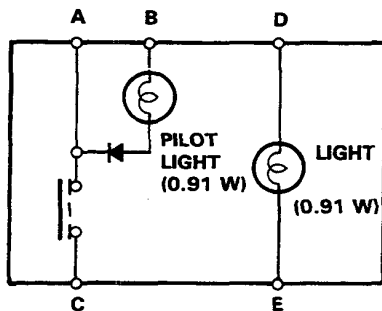
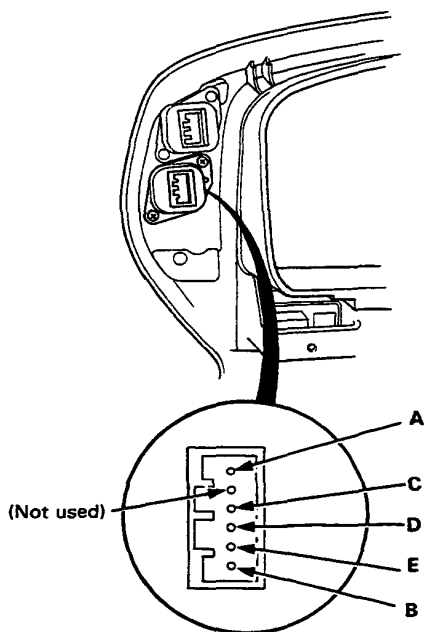

## Relay Test

1. Remove the defogger relay in the dash relay holder.
2. There should be continuity between the A and B terminals when the battery is connected to the C and D terminals. There should be no continuity when the battery is disconnected.

