

# Brake Pad

## Inspection/Replacement (cont'd)

8. Apply MOLYKOTE M77 or equivalent to both surfaces of the shim and back of the pads.

9. Install the brake pads.

NOTE: Apply MOLYKOTE M77 or equivalent between the shims and pads.

10. Install the brake pad shims correctly.

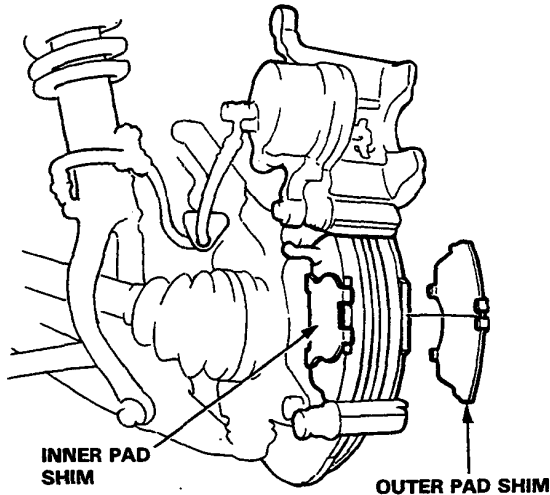

11. Push in the piston so that the caliper will fit over the pads.

12. Pivot the caliper down into position, then install the caliper bolt and tighten it.

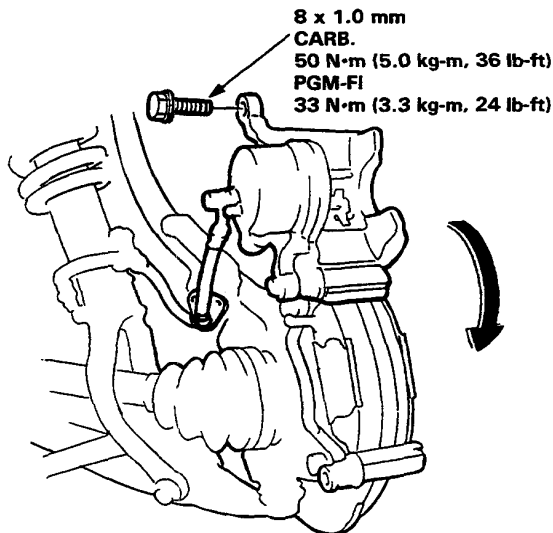

13. Connect the brake hose to the knuckle.

14. Depress the brake pedal several times to make sure the brakes work, then road-test.

# Brake Caliper

## Disassembly

### CAUTION:

- Before reassembling, check that all parts are free of dust and other foreign particles.
- Replace parts with new ones whenever specified to do so.
- Use only clean brake fluid.
- Make sure no dirt or other foreign matter is allowed to contaminate the brake fluid.
- Do not mix different brands of brake fluid as they may not be compatible.
- Do not spill brake fluid on the car, it may damage the paint; if brake fluid does contact the paint, wash it off immediately with water.

1. Remove the banjo bolt and disconnect the brake hose from the caliper.
2. Remove the caliper bolts, then remove the caliper.

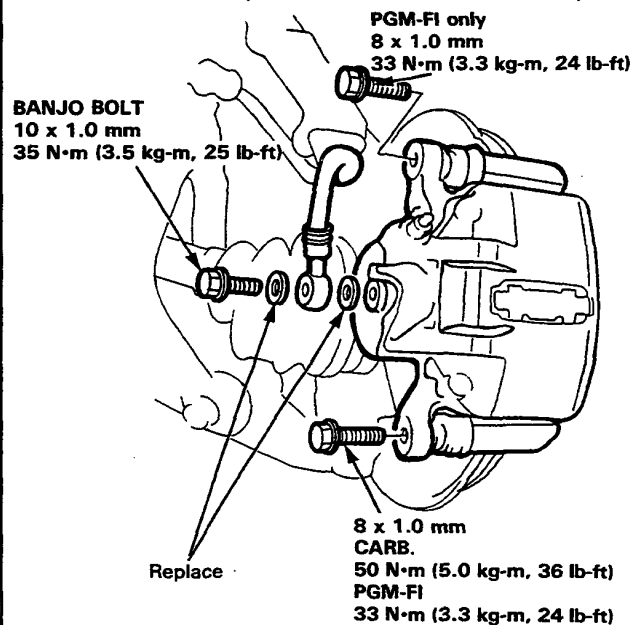

3. Remove the pad spring from the caliper body.

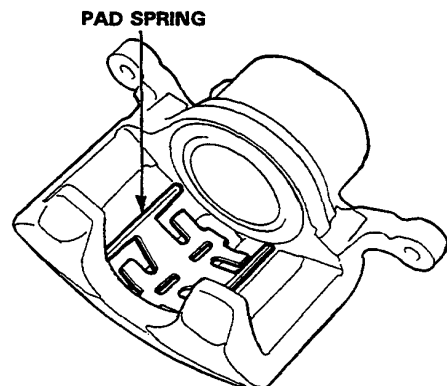

(cont'd)



4. Place a wooden block or shop rag in the caliper opposite the piston, then carefully remove the piston from the caliper by applying air pressure through the brake line hole.

**WARNING**

- Do not place your fingers in front of the piston.
- Do not use high air pressure; use an OSHA-approved 30 PSI nozzle.

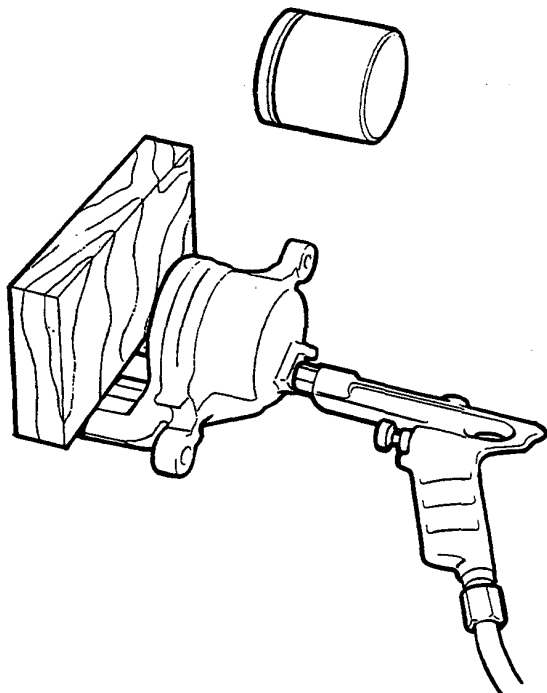

5. Remove the piston boot and piston seal.

**CAUTION:** Take care not to damage the cylinder.

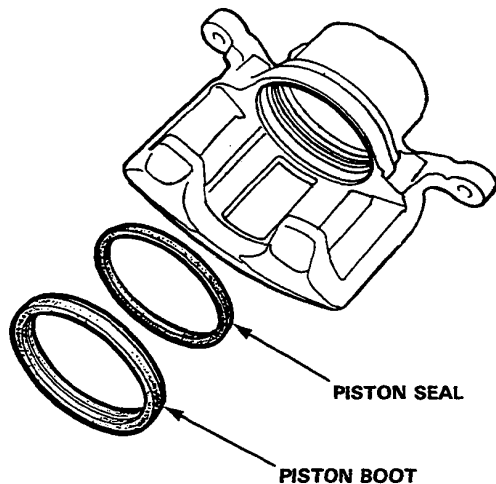

## Reassembly

**CAUTION:**

- Before reassembling, check that all parts are free of dust and other foreign particles.
- Replace parts with new ones whenever specified to do so.
- Use only clean brake fluid.
- Make sure no dirt or other foreign matter is allowed to contaminate the brake fluid.
- Do not mix different brands of brake fluid as they may not be compatible.
- Do not spill brake fluid on the car; it may damage the paint, if brake fluid does contact the paint; wash it off immediately with water.

1. Clean the piston and caliper bore with brake fluid and inspect for wear or damage.
2. Apply silicone grease to a new piston seal, then install the piston seal in the cylinder groove.
3. Apply silicone grease to a new piston boot, then install the piston boot.

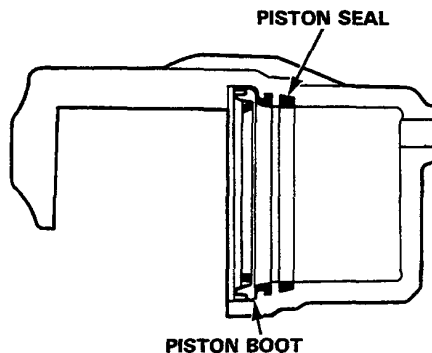

4. Lubricate the caliper cylinder and piston with brake fluid, then install the piston in the cylinder with the dished end facing in.

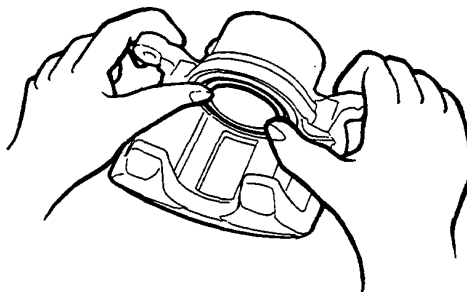

5. Reinstall the caliper in the reverse order of removal.
6. Fill the brake reservoir up and bleed the brake system (page 13-11).