

Brake Booster

Disassembly

1. Scribe an aligning mark across the front and rear booster housings to ensure proper positioning of parts on reassembly.
2. Remove the E-clips, and separate the front booster housing and the rear booster housing.

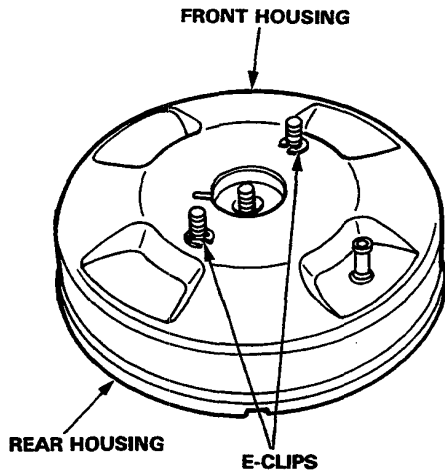

3. Remove the seals and washers from the spring retainer then remove the circlip.

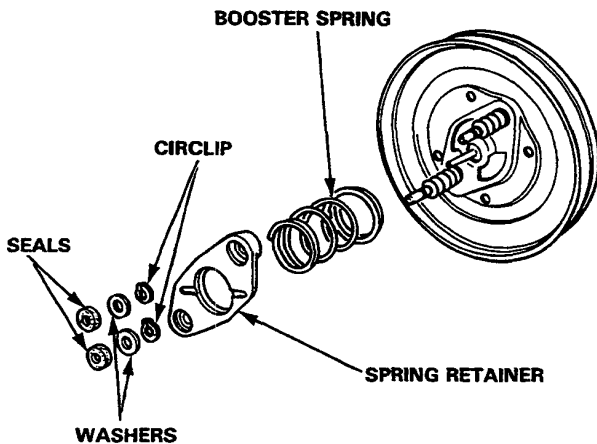

4. Remove the spring retainer and booster spring.

5. Remove the 6 mm flange locknuts and set plate.

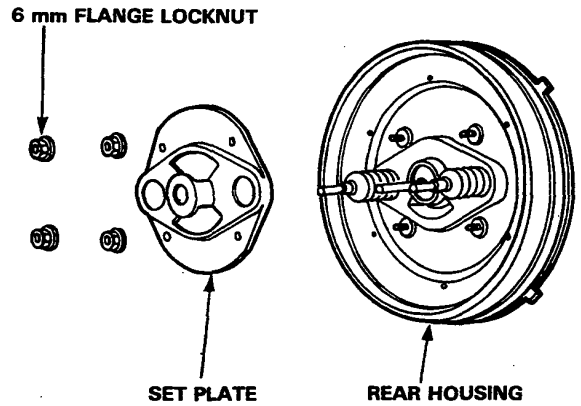

6. Remove the valve holder assembly from the rear housing.

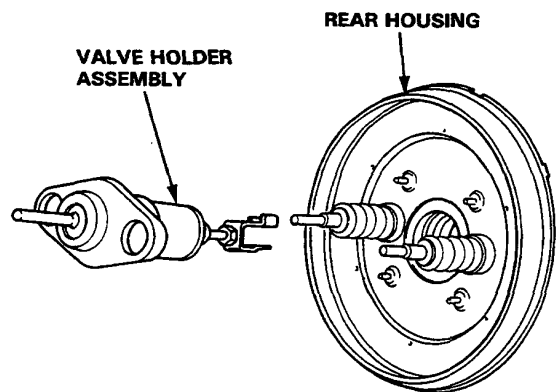



7. Remove the boots from the through-bolts.

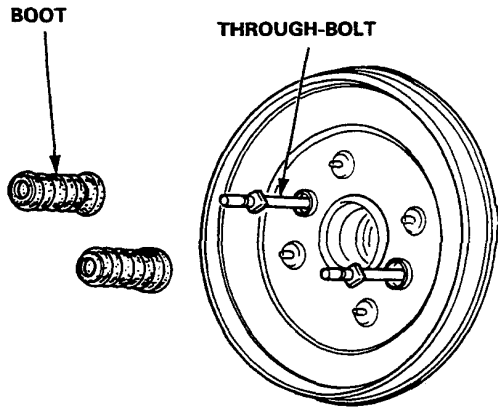

8. Remove the booster plate and diaphragm together from the rear housing.

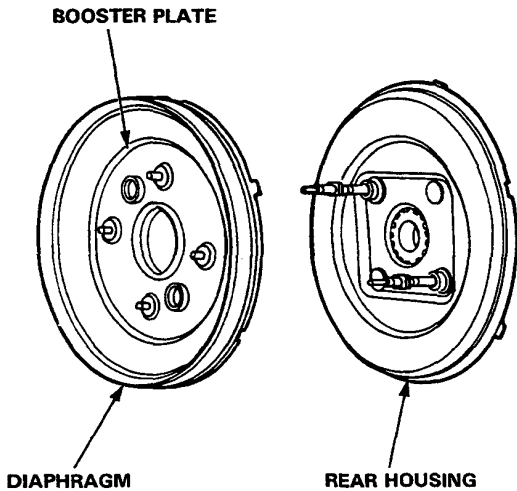

9. Remove the diaphragm from the booster plate.

10. Remove the circlip, then remove the through-bolts and O-rings from the rear housing.

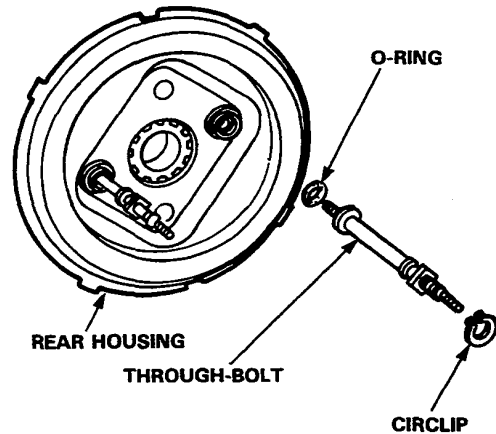

11. Remove the bushing retainer, bushing and piston seal from the rear housing.

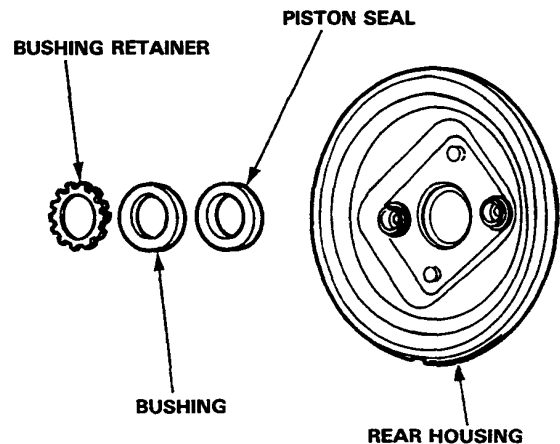

(cont'd)

Brake Booster

Disassembly (cont'd)

12. Remove the output rod, reaction disc and reaction plate from the valve holder assembly.

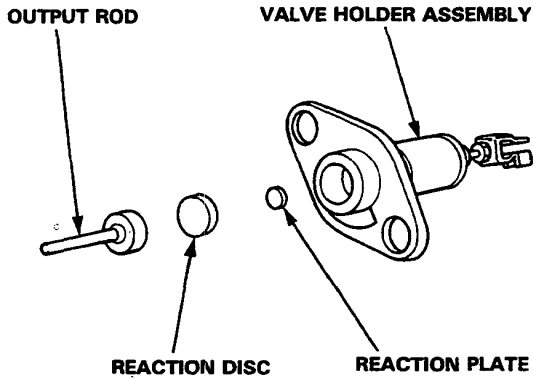

13. Remove the push rod yoke, locknut, star lock nut, adjuster and filter B from the valve holder.

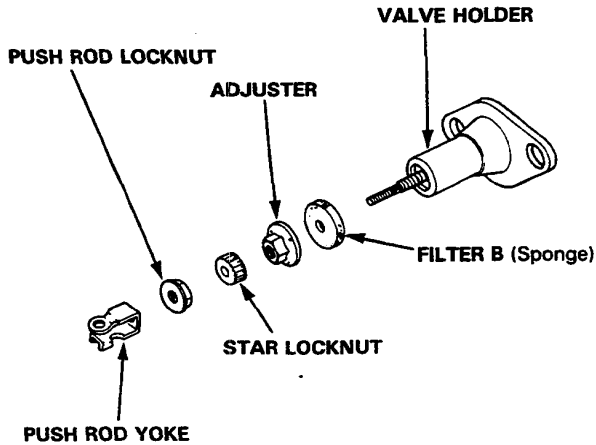

14. Remove the push rod retainer, then remove the push rod from the valve holder assembly.

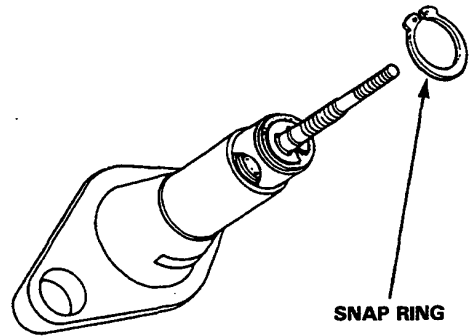

15. Remove the E-clip from the push rod.

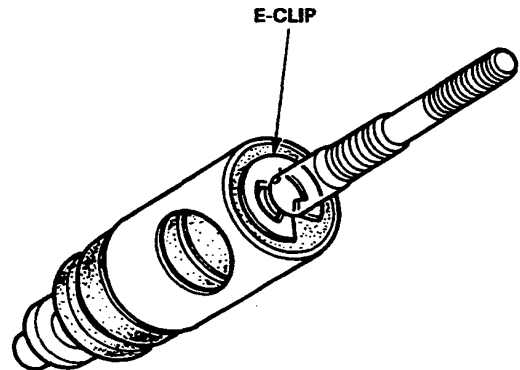



16. Remove filter A, the spring seat, valve springs, valve holder and poppet valve from the push rod.

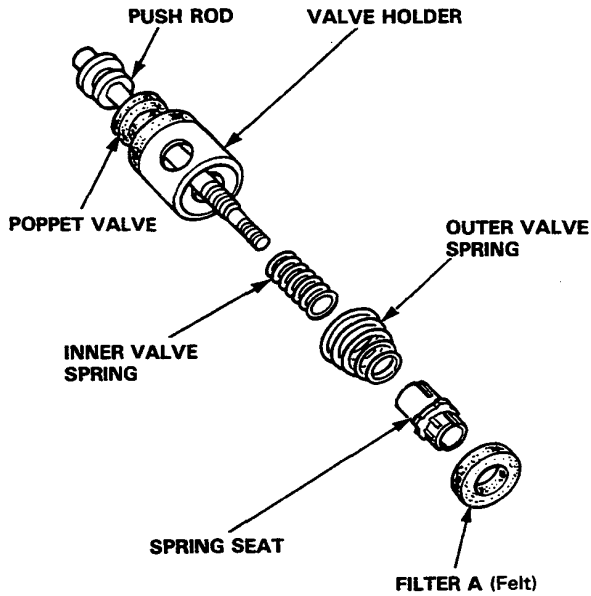

Rebuild Kit



E-CLIP



SEAL



10 mm CIRCLIP



REACTION DISC



BOOT

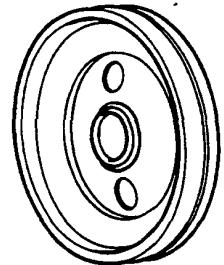

DIAPHRAGM



POPPET VALVE



FILTER A (Felt)



E-CLIP



FILTER B (Sponge)



SNAP RING



BUSHING RETAINER



BUSHING



PISTON SEAL



19 mm CIRCLIP



O-RING



6 mm FLANGE LOCKNUT



SILICONE GREASE