



Four Wheel Steering-4WS

Using Toe Inspection Gauge:

Preparation

1. Check the tire pressure.
2. Remove the cap bolt from the rear steering gearbox, install the center lock pin in the rear steering gearbox and determine the neutral position.

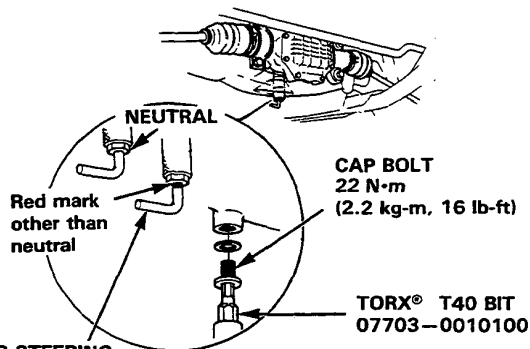

**REAR STEERING
CENTER LOCK PIN
07HAJ-SF10201**

3. Check the steering wheel angle.
 - If it is more than 20 mm (0.787 in) (6°) off center, adjust it as follows:

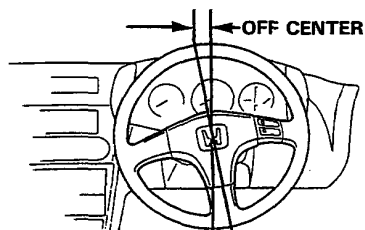

OFF CENTER

- 1) Remove the center lock pin from the rear steering gearbox.
- 2) Loosen the steering wheel nut. (Do not remove the steering wheel this time.)
- 3) Install the center lock pin in the rear steering gearbox.
Turn the steering wheel right or left slightly until the center lock pin seats fully. The red mark on the pin should not be visible.
Do not turn the steering wheel quickly when the center lock pin is seated and do not force past the locking point after the pin is seted, or the gearbox may be damaged.
- 4) Remove the steering wheel and reset it in the position as close as to center.
- 5) Remove the center lock pin from the rear steering gearbox.

- 6) Tighten the steering wheel with a new steering wheel nut.

TORQUE: 50 N·m (5.0 kg-m, 36 lb-ft)

NOTE: On steering wheel nut removal/installation, be sure to remove the center lock pin from the rear steering gearbox to prevent damage to the gearbox.

4. Place the car on level surface.
5. Release the parking brake.
6. Move the car 1 m (3.28 ft.) forward and take off the slack in the bushing.
7. Turn the steering wheel to the straight-ahead position and hold it.
8. Alignment should be checked/adjusted in one continuous procedure: caster, front camber, rear camber, rear toe, front toe and re-check.

Front Caster:

1. Install the Wheel Alignment Gauge Attachments on the wheels.
NOTE: Make sure the wheel hubs are clean and rust-free before installing the wheel alignment attachments.
2. Install a camber/caster gauge on the Wheel Alignment Gauge Attachment and apply the front brake. Turn the wheel 20° inward.
3. Turn the adjust screw so that the bubble in the caster gauge is at 0°
4. Turn the wheel 20° outward and read the caster on the gauge with the bubble at the center of the gauge.

Caster Angle: 2°20' ± 30'

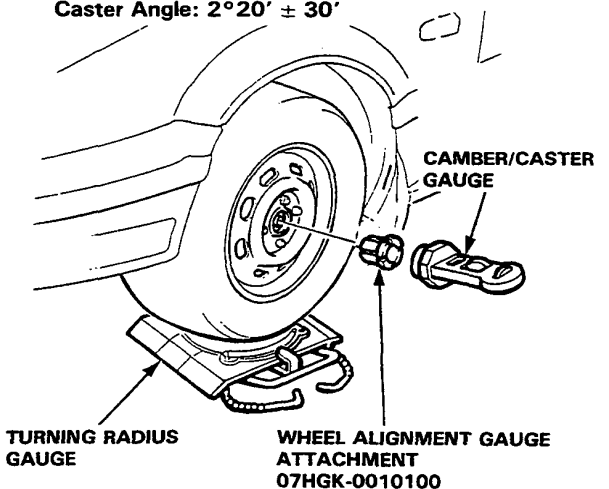

5. If adjustment is required, record the caster reading, then go to step 6. If adjustment is not required, proceed to step 11.

(cont'd)

Wheel Alignment

Four Wheel Steering (4WS) (cont'd)

- Loosen the radius rod attaching bolts at the lower arm.

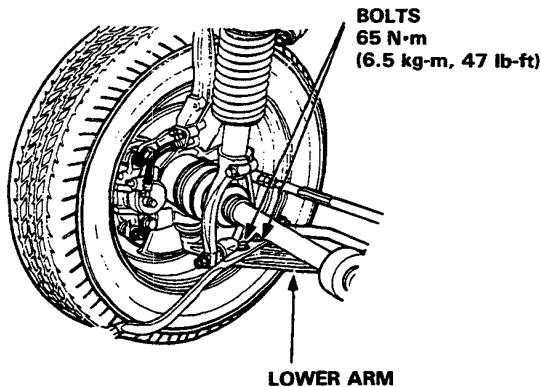

- Loosen the self-locking nut on the end of the radius rod.
- Adjust the caster by turning the radius rod adjuster as required.

To increase: Turn the adjuster in.
To decrease: Turn the adjuster out.

NOTE: Turning the adjuster one full turn moves the radius rod 1.5 mm (0.06 in) and changes the caster $0^{\circ} 20'$.

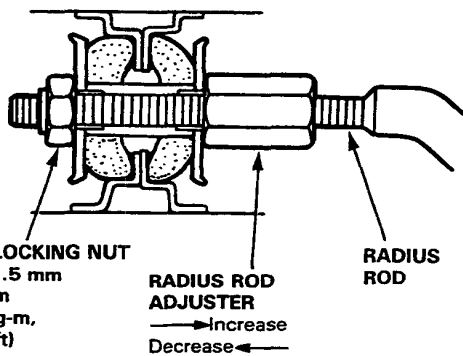

- Tighten the radius rod attaching bolts at the lower arm.
- Hold the radius rod adjuster nut in place and tighten self-locking nut.
- Recheck the caster angle.

Front Camber:

- Return the steering wheel to the straight-ahead position.
- Read the front camber on the gauge with the bubble at the center of the gauge.

Front Camber Angle: $0^{\circ} 00' \pm 1^{\circ}$

- Adjust the camber by loosening the upper arm lock nut and moving the knuckle/hub assembly.

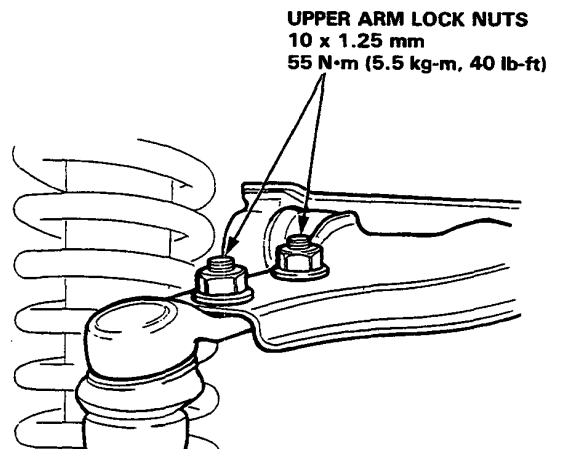

Rear Camber:

- Read the rear camber on the gauge with the bubble at the center of the gauge.

Rear Camber: $-0^{\circ} 20' \pm 30'$

NOTE: The difference between right and left camber should be within $20'$.

- Adjust the rear camber by loosening the upper arm lock nuts and moving the knuckle/hub assembly.

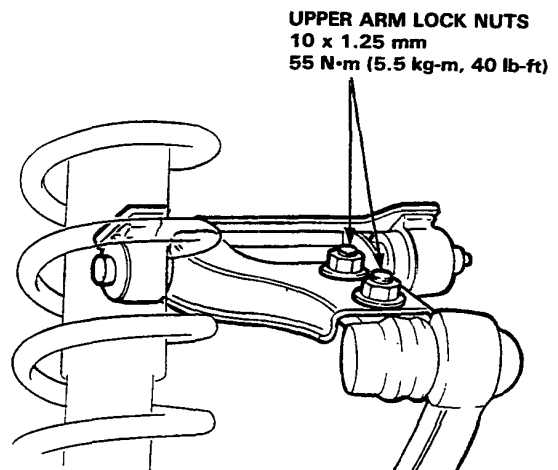

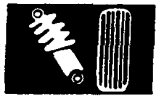

Toe:

17. Install the toe inspection gauge set attachment on each wheel and turn the wheel diameter adjusting screws and tire diameter adjusting screw right or left so that the attachment fits on the wheel disc securely.

- Be sure that the tread compensation screw is on the front of the front wheel disc and on the rear of the rear wheel disc.

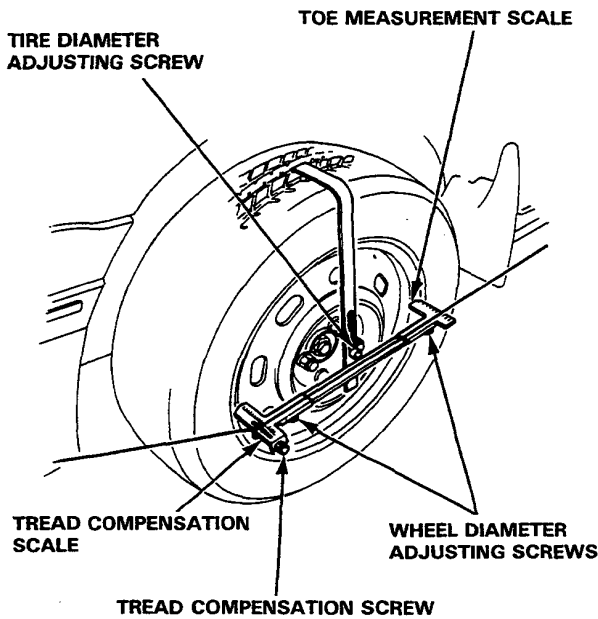

- Align the center of the gauge with the center of the wheel.

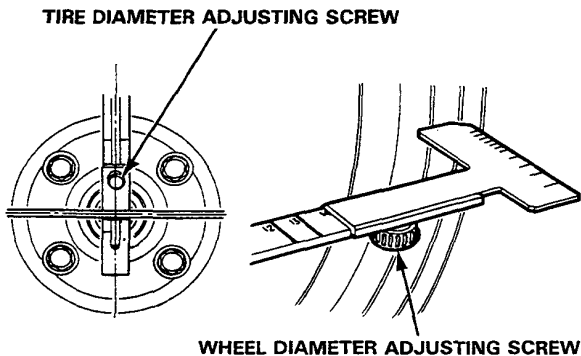

- Set the toe inspection gauge on each wheel so that it makes right angle to the wheel.

NOTE: Be sure that the toe gauge does not interfere with the balance weight of the wheel.

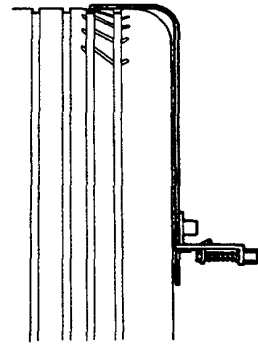

18. Set the tread compensation scale on the front wheel at 50 and on the rear wheel at 55.

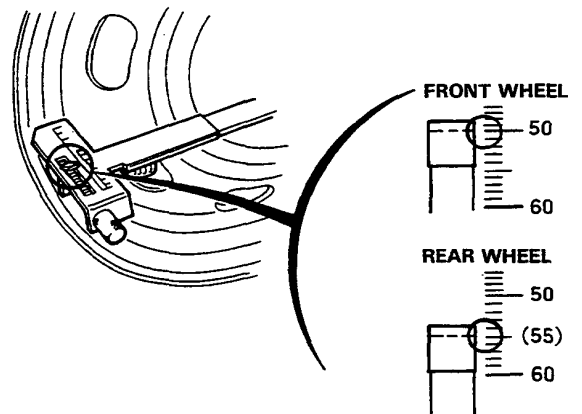

(cont'd)

Wheel Alignment

Four Wheel Steering (4WS) (cont'd)

19. Attach the string to the bumper and secure with the hook A.
20. Route the string around the car and secure with the hook B. Be sure that there is no slack in the string.

NOTE: Be sure that the string does not contact the exhaust pipe.

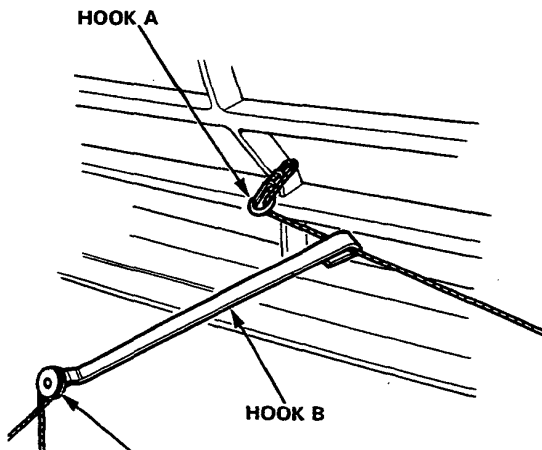
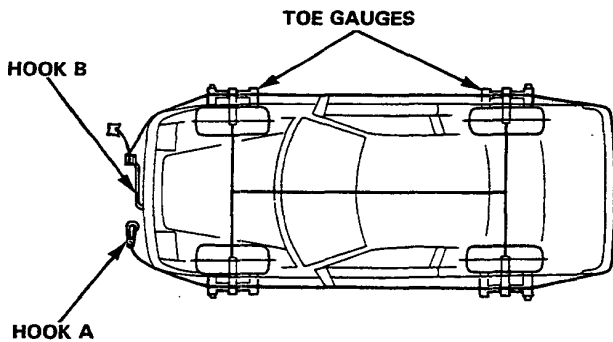

Secure the string; there should be no slack.

21. Hook the string on each tread compensation scale.

- Keep a slight clearance between the string and toe gauge.
- Be sure that the toe gauge is parallel with the ground.

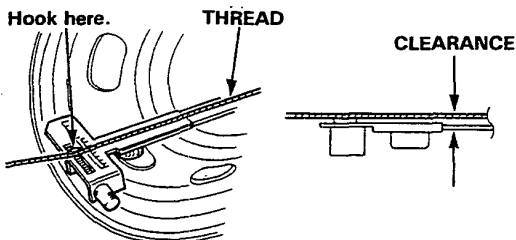

22. Read the tread compensation scale and measurement scale and calculate their difference.

- Measurement varies according to the angle you are looking. Read all the measurements at the same height.
- Check the side of the string that is closer to a division of the tread compensation scale, and read the measurement scale at the same side of the string.
- Toe of all wheels is zero if the measurements of the tread compensation scale and measurement scale on each wheel are the same.

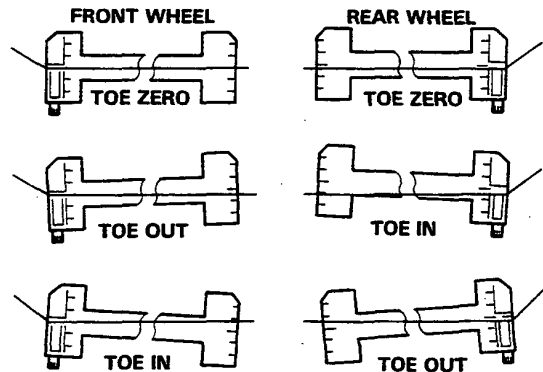

23. Adjust so that the front toe and rear toe are 0 when the front camber is 0° and rear camber $-0^\circ 20'$.

24. After the front and rear toe are adjusted to zero, loosen the right and left rear wheel tie-rods 45° and set the rear toe-in to 2 mm (0.079 in).

25. After adjusting, tighten the tie-rod locknuts.

NOTE: Reposition the tie-rod boots if twisted or displaced after adjustment has been made.

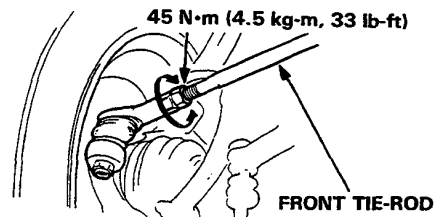

26. Recheck the camber. If camber still as specified alignment is finished.

Front Camber Angle: $0^\circ 00' \pm 1^\circ$
 Rear Camber Angle: $-0^\circ 20' \pm 30'$



Using Full-floating Turn Table:

Preparation

NOTE: Alignment equipment must be capable of 4 wheel alignment and must use full-floating turntables at all four wheels.

1. Check the tire pressure.
2. Jack up the car and temporarily place on safety stands.
3. Install the 4WS Center Lock Pin (see page 12-7). Install lock pins in the full floating turntables.
4. Lower the car onto the turntables. Remove the turntable lock pins and "settle" the suspension by pushing the car up and down several times. Remove the 4WS Center Lock Pin.
5. Check the steering wheel angle. If significantly off center, it may be necessary to remove the steering wheel and reposition it on the splines (page 12-7). Turn the steering wheel to the straight-ahead position.

NOTE: If the wheel removal is necessary, loosen the nut, then temporarily reinstall the 4WS Center Lock Pin before repositioning the wheel.

6. Alignment should be checked/adjusted in one continuous procedure: caster, front camber, rear camber, rear toe, front toe and re-check.

Front Caster:

1. Install the Wheel Alignment Gauge Attachments on the Wheels.

NOTE: Make sure the wheel hubs are clean and rust-free before installing the wheel alignment attachment.

2. Install a camber/caster gauge on the Wheel Alignment Gauge Attachment and apply the front brake. Turn the wheel 20° inward.
3. Turn the adjust screw so that the bubble in the caster gauge is at 0°.
4. Turn the wheel 20° outward and read the caster on the gauge with the bubble at the center of the gauge.

Caster Angle: 2° 20' ± 30'

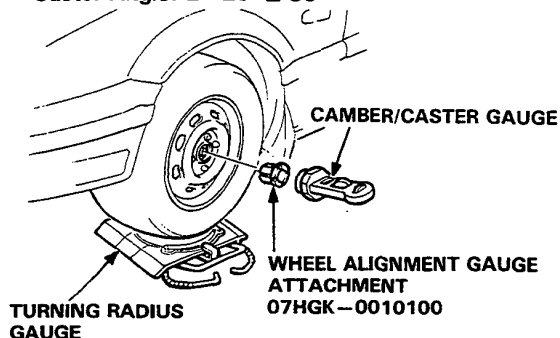

5. If adjustment is required, record the caster reading, then go to step 6. If adjustment is not required, proceed to step 11.
6. Loosen the radius rod attaching bolts at the lower arm.

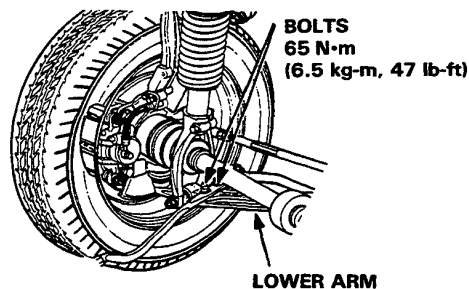

7. Loosen the self-locking nut on the end of the radius rod.
8. Adjust the caster by turning the radius rod adjuster as required.

To increase: Turn the adjuster in.

To decrease: Turn the adjuster out.

NOTE: Turning the adjuster one full turn moves the radius rod 1.5 mm (0.06 in) and changes the caster 0° 20'.

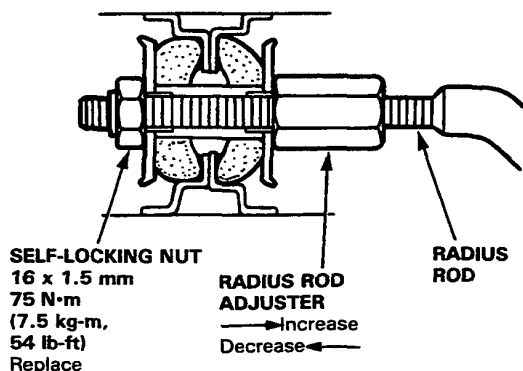

9. Tighten the radius rod attaching bolts at the lower arm.
10. Hold the radius rod adjuster nut in place and tighten self-locking nut.
11. Recheck the caster angle.

(cont'd)

Wheel Alignment

Four Wheel Steering-4WS (cont'd)

Front Camber:

12. Return the steering wheel to the straight-ahead position.
13. Read the front camber on the gauge with the bubble at the center of the gauge.

Front Camber Angle: $0^{\circ} 00' \pm 1^{\circ}$

14. Adjust the camber by loosening the upper arm lock nut and moving the knuckle/hub assembly.

UPPER ARM LOCK NUTS
10 x 1.25 mm
55 N·m (5.5 kg-m, 40 lb-ft)

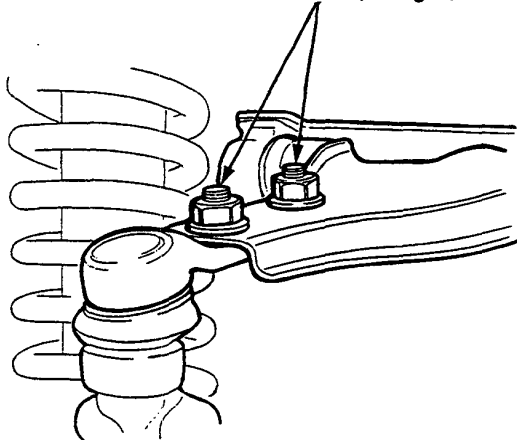

Rear Camber:

15. Read the rear camber on the gauge with the bubble at the center of the gauge.

Rear Camber: $-0^{\circ} 20' \pm 30'$

NOTE: The difference between right and left camber should be within 20'.

16. Adjust the rear camber by loosening the upper arm lock nuts and moving the knuckle/hub assembly.

UPPER ARM LOCK NUTS
10 x 1.25 mm
55 N·m (5.5 kg-m, 40 lb-ft)

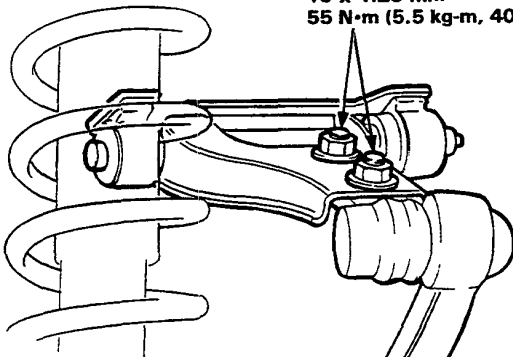

Toe:

17. Check the rear toe-in.
Right Rear : 1 mm
Left Rear : 1 mm
Total : 2 ± 2 mm (0.08 ± 0.08 in)

NOTE: Left and right toe should be the same.

- If adjustment is required, go to step 18.
- If no adjustment is required, proceed to step 20.

18. Loosen the tie-rod locknuts.
19. After adjusting, tighten the tie-rod locknuts.

NOTE: Reposition the tie-rod boots if twisted or displaced after adjustment has been made.

LOCKNUT
12 x 1.25 mm
45 N·m (4.5 kg-m, 33 lb-ft)

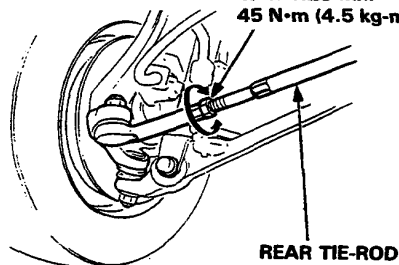

20. Check the front toe-in:
Right Front : 0 mm
Left Front : 0 mm
Total : 0 ± 2 mm (0 ± 0.08 in)

NOTE: Left and right toe should be the same.

- If adjustment is required, go to step 21.
- If no adjustment is required, proceed to step 22.

21. Loosen the tie-rod locknut and turn the tie-rod until toe-in is correct.
22. After adjusting, tighten the tie-rod locknuts.

NOTE: Reposition the tie-rod boots if twisted or displaced after adjustment has been made.

LOCKNUT
12 x 1.25 mm
45 N·m (4.5 kg-m, 33 lb-ft)

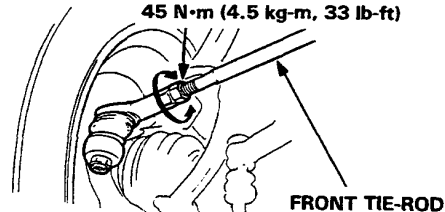

23. Recheck the camber. If camber still as specified alignment is finished.

Front Camber Angle: $0^{\circ} 0' \pm 1^{\circ}$
Rear Camber Angle: $-0^{\circ} 20' \pm 30'$