

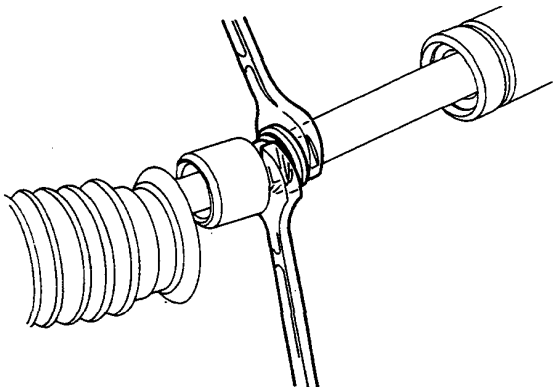

Overhaul (4WS)

1. Remove the steering gearbox assembly (page 17-42).
2. Remove the control valve assembly (page 17-36).
3. Straighten the tab of the lock washer.
4. While holding the steering rack with a 22 mm wrench, remove the tie-rod with a 17 mm wrench.



5. Slide the steering rack into the cylinder housing until the end is projected 63 mm (2.5 in.) from the rack bushing retainer.

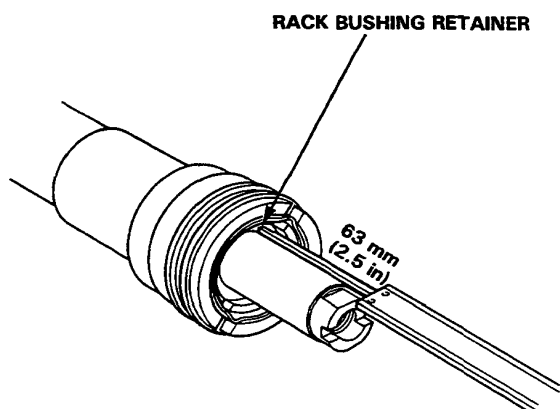

6. Loosen the rack screw lock nut, and turn off the guide screw.

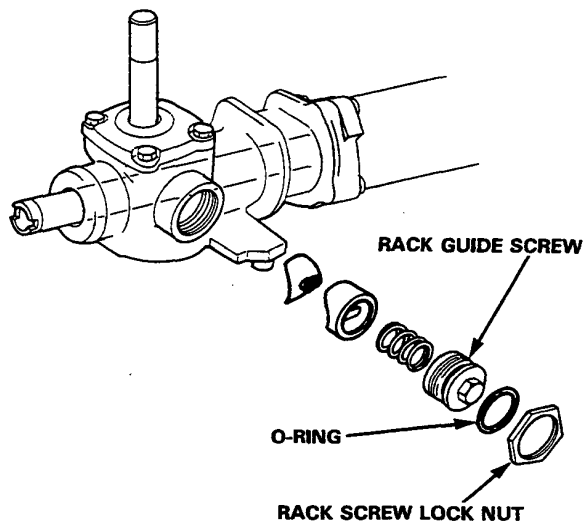

7. Remove the 28 mm internal snap ring from the bottom of the gear housing.

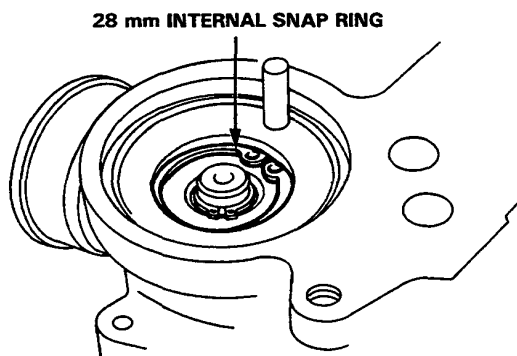

(cont'd)

Steering Gearbox

Overhaul (4WS) (cont'd)

8. Remove the pinion from the gear housing by tapping it lightly.

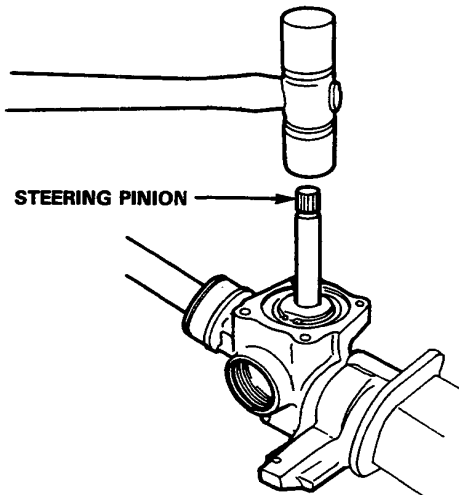

9. Check the pinion lower ball bearing for play.

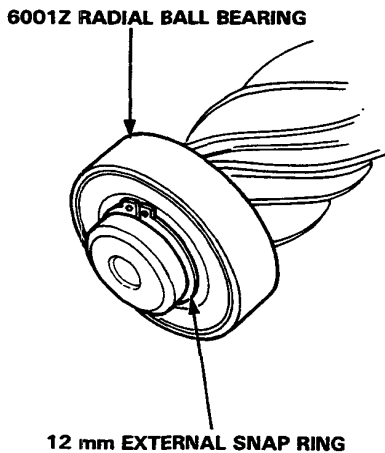

10. If the bearing is noisy or has excessive play, remove the 12 mm snap ring and remove the bearing using a commercially available bearing puller.

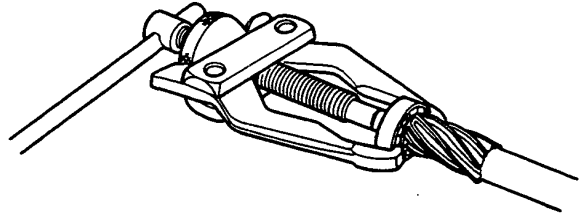

11. Remove the dust seal by removing the seal band.

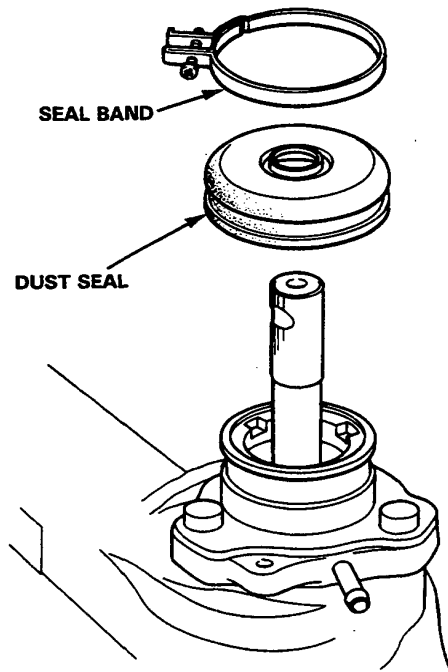



12. Remove the three driven pinion holder bolts using a TORX® bit T40.

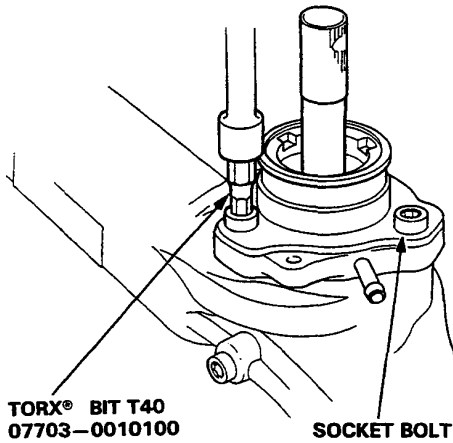

13. Remove the washer from the driven pinion holder.
14. Scribe a mark on the edge of the holder which aligns up with the line mark on the front gear housing B.
15. Pull the pinion holder out of the front gear housing B while turning it clockwise.

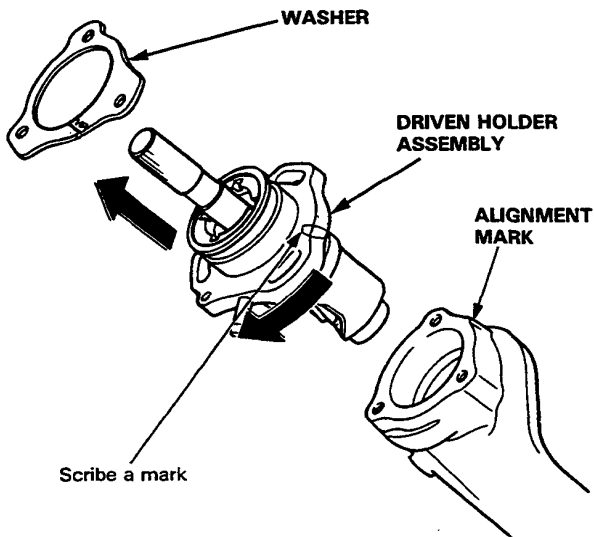

16. Remove the four bolts from the end of the cylinder housing.
17. Slide the front gear housing B off the rack.
18. Remove the magnet and cylinder spring from the gear housing.

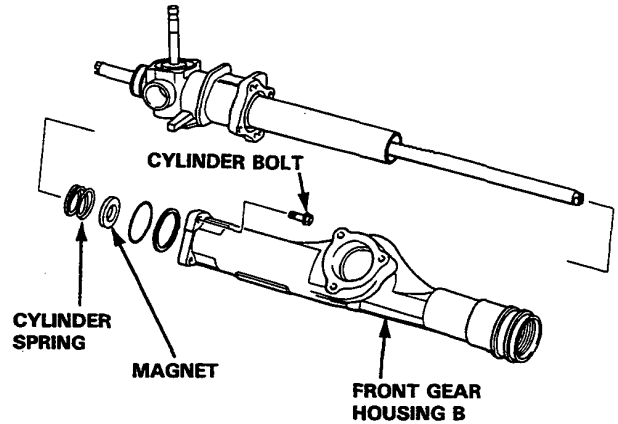

19. Place a front gear housing B in a vise with soft jaws.

NOTE: Be careful not to damage the housing flange by over-tightening the vise.

20. Straighten the locking tab of the cylinder end screw, and remove the screw using the special tool.

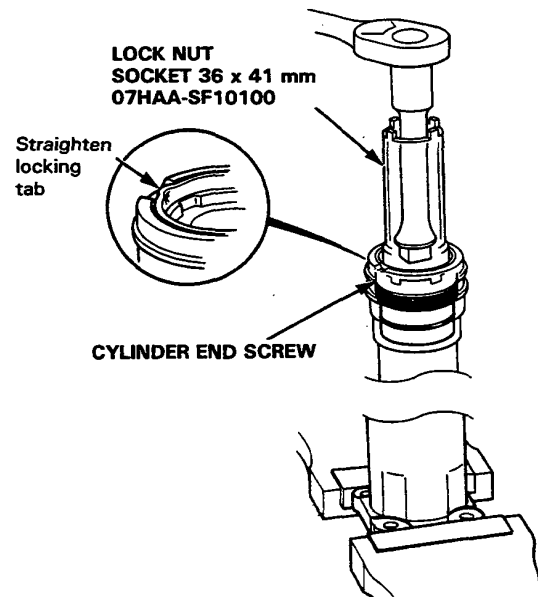

(cont'd)

Steering Gearbox

Overhaul (4WS) (cont'd)

21. Reaching through the driven pinion hole of the front gear housing B, install the smaller diameter end of the special tool into the rack bushing A.
22. Remove the rack bushing retainer by lightly tapping the end of the special tool with a drift or equivalent.

CAUTION: Take care not to damage the inner wall of the cylinder.

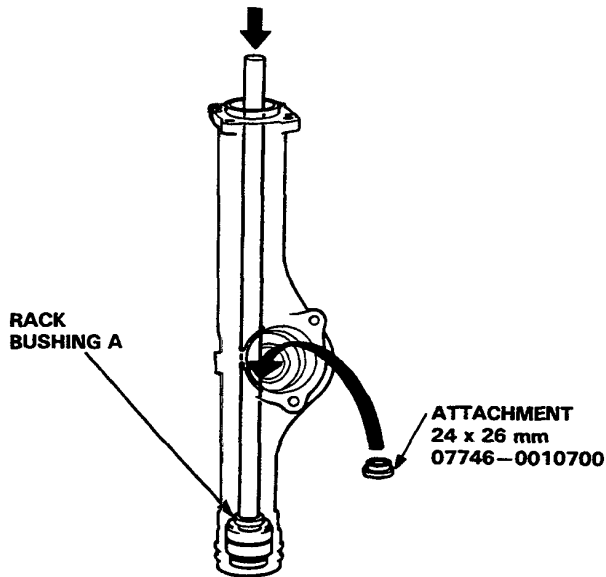

23. Remove the O-ring cylinder seal, and rack bushing A.

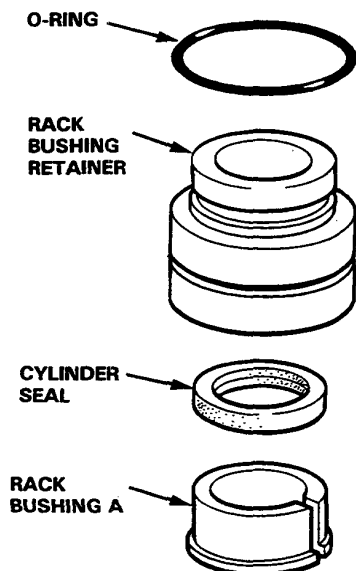

24. Remove the cylinder, cylinder seal retainer, cylinder cap and steering rack from the gear housing.

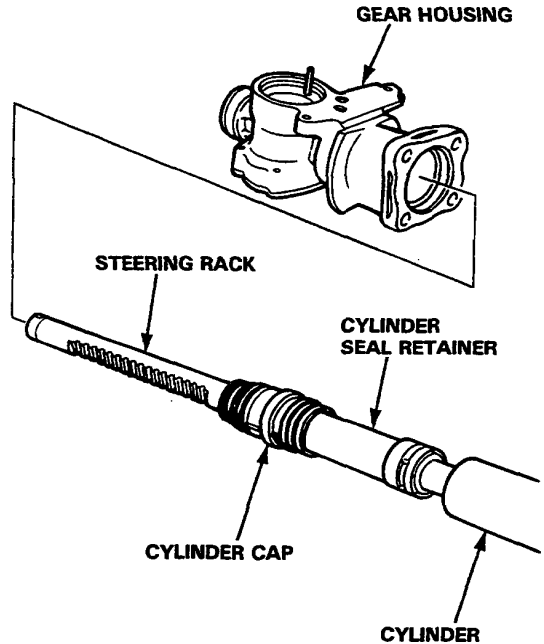

25. Remove the retainer washer from the gear housing.

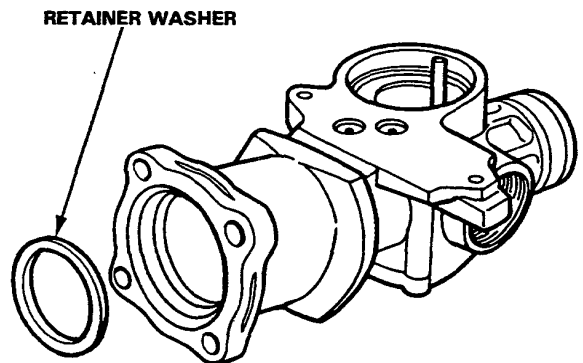



26. Remove the gear housing cap from the gear housing by removing the four 6 mm flange bolts.
27. Remove the steering pinion seal from the gear housing cap.
28. Remove the 46 x 1.5 mm O-ring from the gear housing.

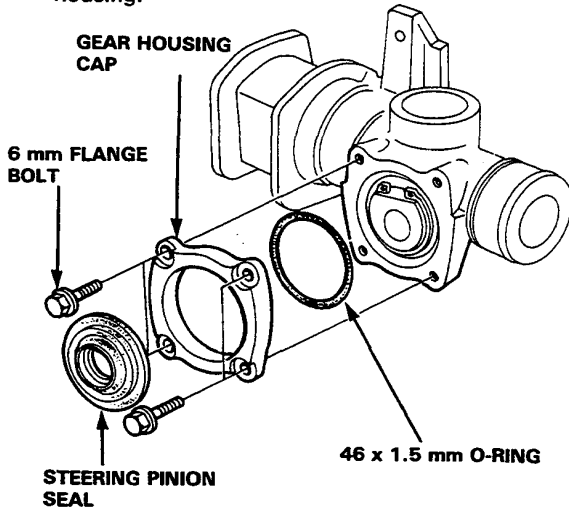

29. Check the upper bearing for faulty movement and excessive play, and for contaminated grease.

- Check the pinion holder for play. If they are good, go on step 30 in page 11-65.
- If the bearing is faulty, or pinion holder has excessive play, disassemble the gear housing in the following manner.
- Remove the 30 mm snap ring from the pinion holder.

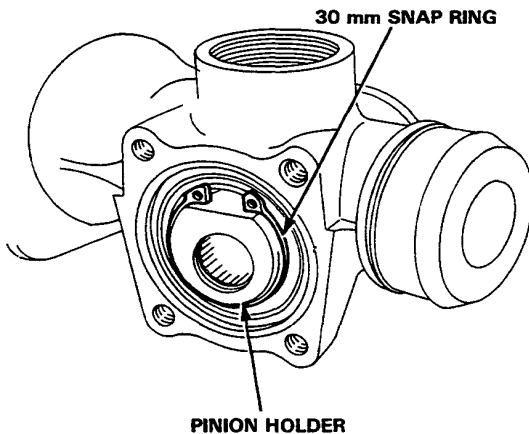

- Remove the pinion holder from the gear housing.

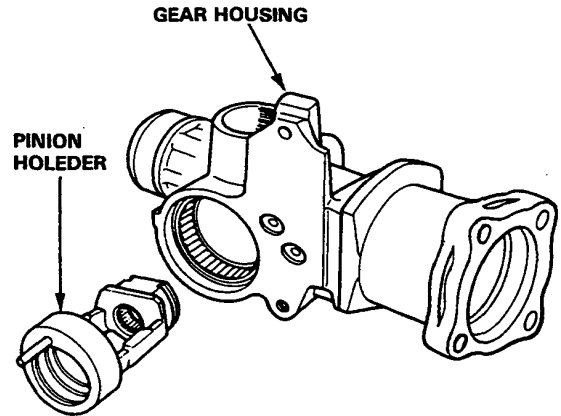

- Remove the ball bearing from the gear housing.

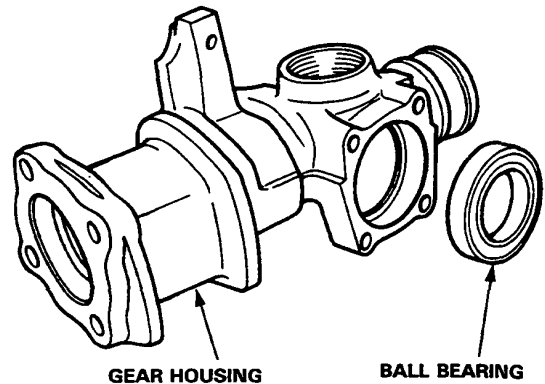

(cont'd)

Steering Gearbox

Overhaul (4WS) (cont'd)

- Check the needle roller bearings in the pinion holder and in the gear housing for damage; if they are OK, pack them with grease.

NOTE: If the bearings are damaged, replace the gear housing as a sub-assembly.

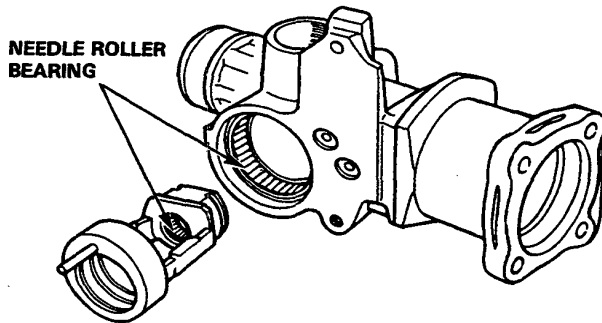

- Pack a new upper bearing with grease, then drive the bearing into the gear housing using the special tools.

NOTE: Install the bearing with its sealed end facing out.

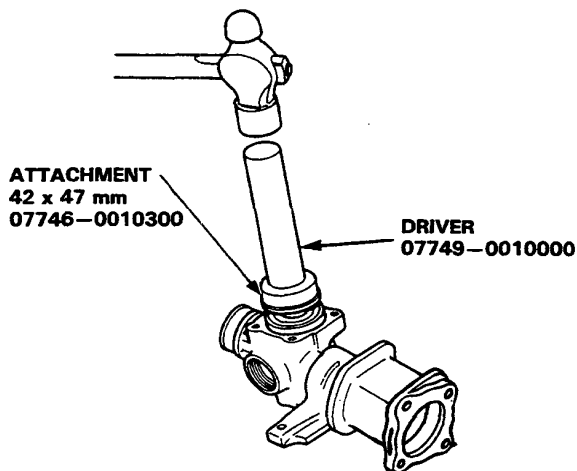

- Install the pinion holder in the gear housing.

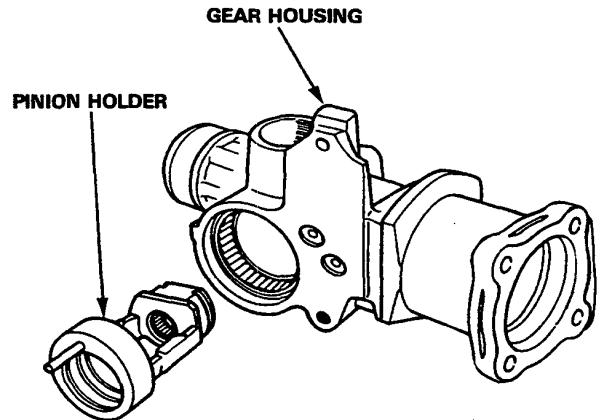

- Reinstall the 30 mm snap ring in the pinion holder.

NOTE:

- Install the 30 mm snap ring with its tapered side facing out.
- Snap ring ends must be aligned with the flat areas of the pinion holder.

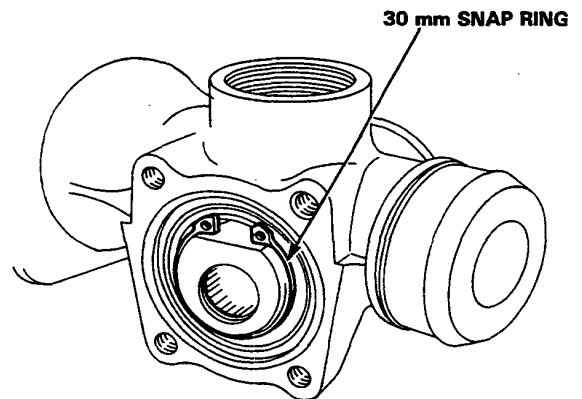



30. Remove the cylinder and seal retainer from the steering rack.

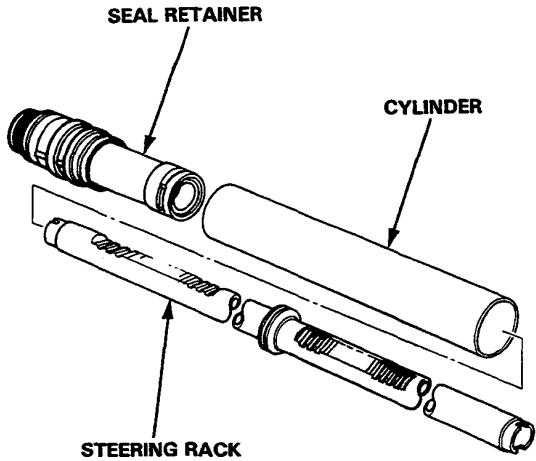

31. Remove the 27.5 mm O-ring and circlip from the seal retainer, then remove the cylinder cap.

32. Remove the 39.0 x 1.5 mm O-rings from the cylinder cap.

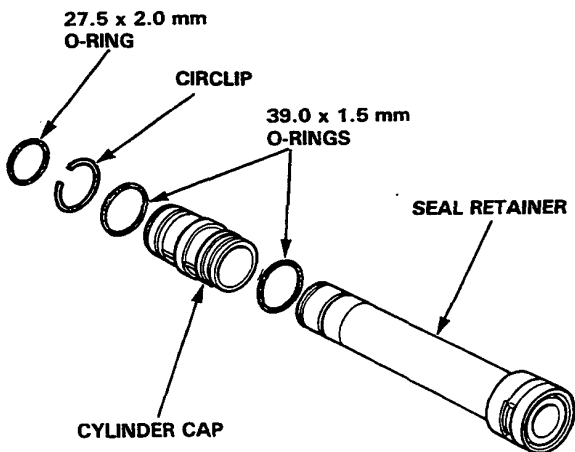

33. Remove the bushing stopper ring and rack bushing B from the seal retainer.

34. Remove the cylinder end seal.

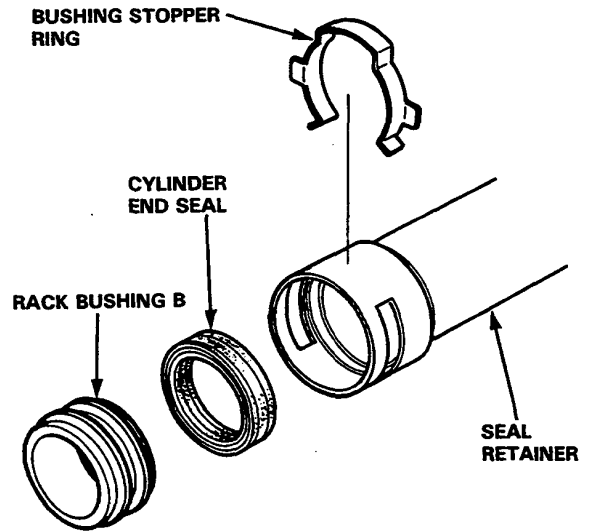

35. Remove the piston seal ring from the steering rack using a narrow screwdriver.

36. Remove the 33.5 x 2.4 mm O-ring.

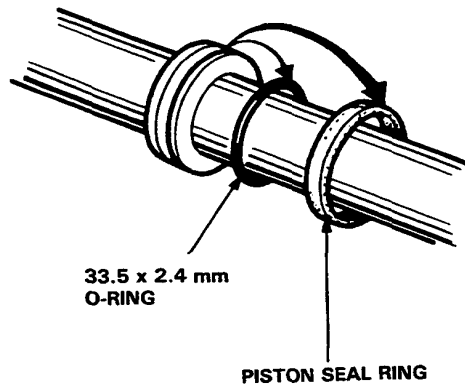

(cont'd)

Steering Gearbox

Overhaul (4WS) (cont'd)

37. Fit a new 33.5 x 2.4 mm O-ring in the groove of the steering rack.

NOTE: Install the 33.5 mm x 2.4 mm O-ring with the projected side facing out.

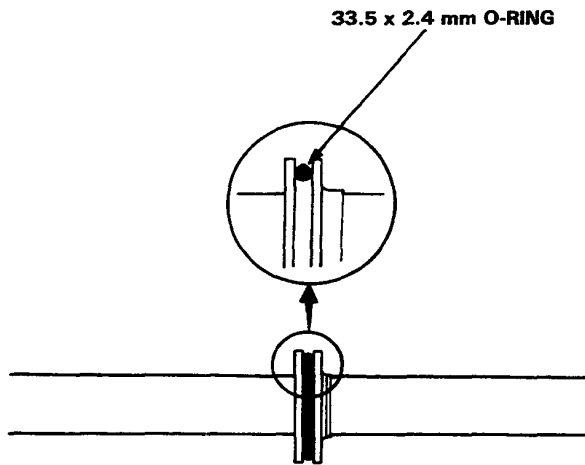

38. Coat the special tool with power steering fluid, and slide the tool onto the steering rack starting with the larged end until it stop. Slide the piston seal ring over the special tool and into the groove on the steering rack.

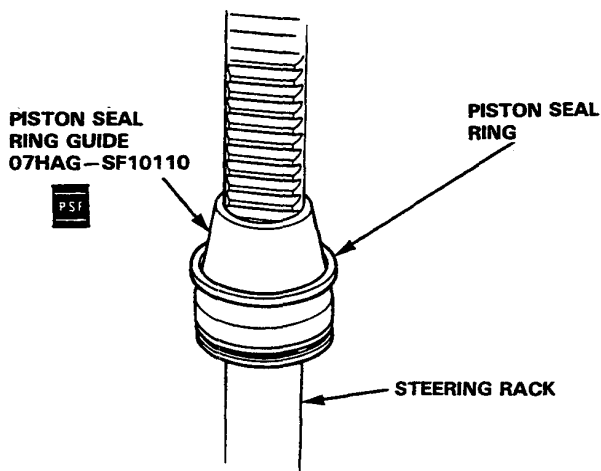

39. Coat the piston seal ring on the steering rack with power steering fluid.

40. Coat the inner surfaces of the special tool "Piston Seal Ring Sizing Tool" with power steering fluid, and place the tool over the piston seal ring.

Move the tool up and down to seat the piston seal ring on the steering rack.

NOTE: Keep the piston seal ring in the non-tapered part of the tool.

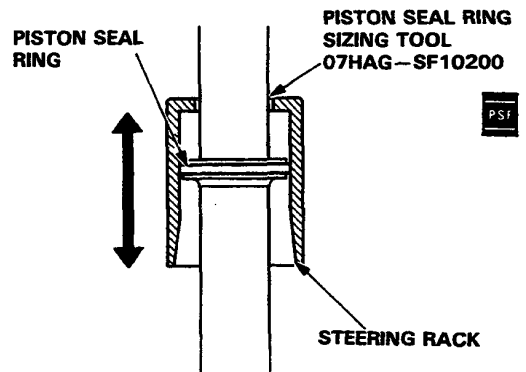

41. Grease the sliding surfaces of the two 39.0 x 1.5 mm O-rings, and fit them onto the cylinder cap.

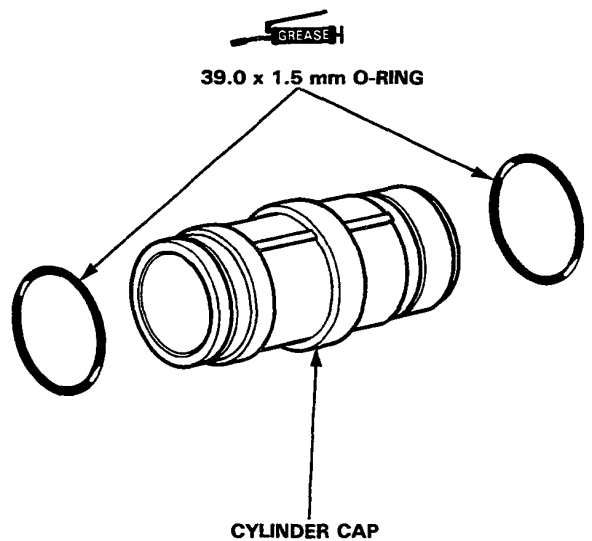



- 42. Install the cylinder cap on the seal retainer.
- 43. Install the circlip on the seal retainer.
- 44. Install the 27.5 x 2 mm O-ring on the seal retainer.

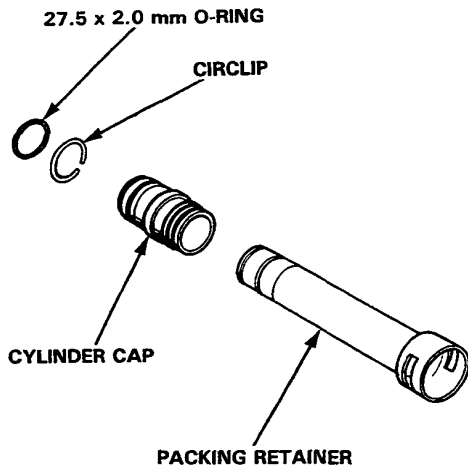

- 45. Install the rack bushing B on the steering rack.

NOTE: Grease the sliding surface of the steering rack bushing B before installing it on the steering rack.

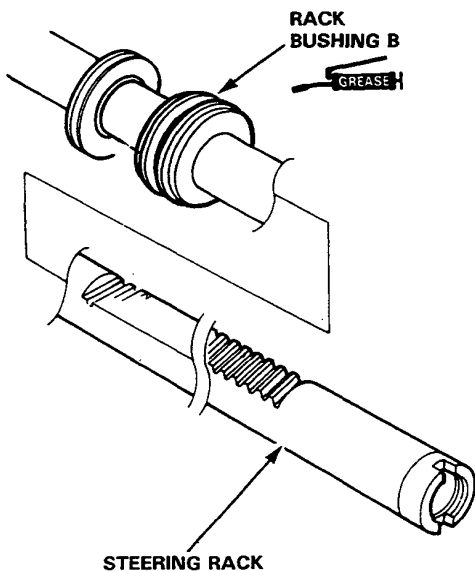

- 46. Grease the sliding surface of a new cylinder end seal and install it onto the special tool.

NOTE: The groove of the cylinder end seal should face away from the special tool.

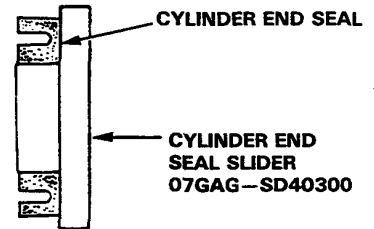

- 47. Grease the steering rack, slide the special tool over the steering rack past the gear teeth area.

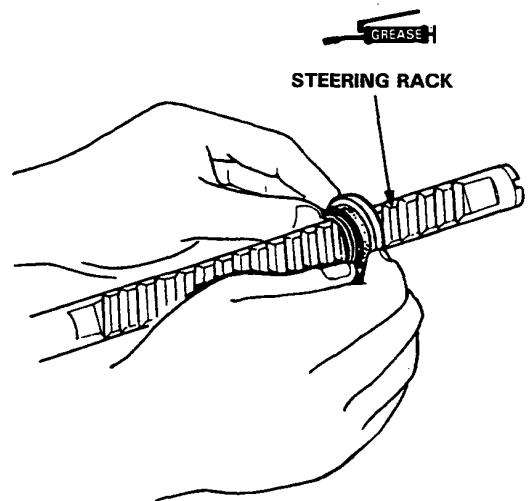

(cont'd)

Steering Gearbox

Overhaul (4WS) (cont'd)

48. Slide the cylinder end seal off the special tool and remove the tool from the cylinder end seal.

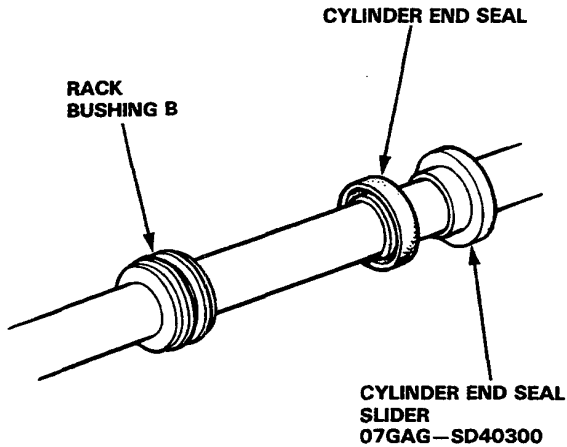

49. Fit the seal retainer on the steering rack.

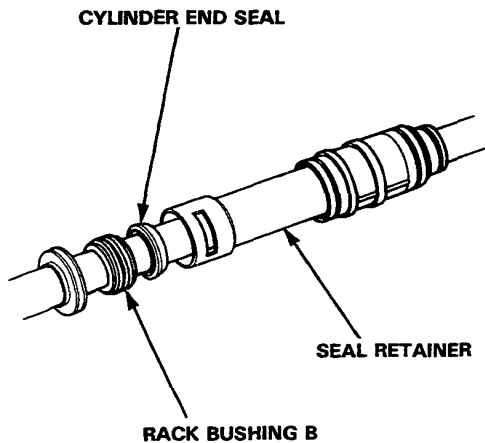

50. Push the rack bushing B toward the seal retainer by hand until the cylinder end seal is seated in the retainer.

Fit the bushing stopper ring in the groove of the seal retainer securely.

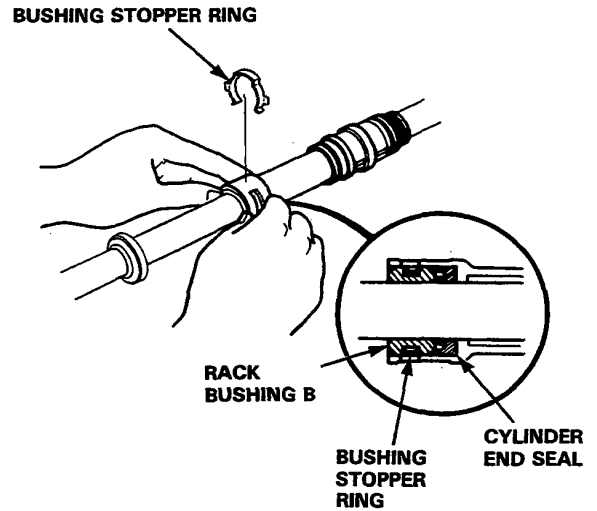

51. Install the retainer washer in the gear housing.

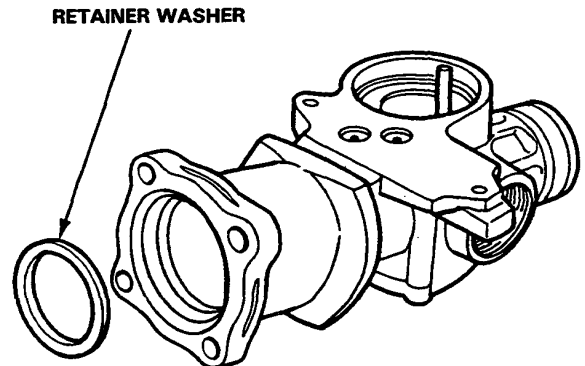



52. Place the gear housing on the work bench and insert the seal retainer and steering rack into the gear housing.
53. Coat the inside of the cylinder with power steering fluid, slide it over the rack and into the gear housing; press it into the housing until it seats.

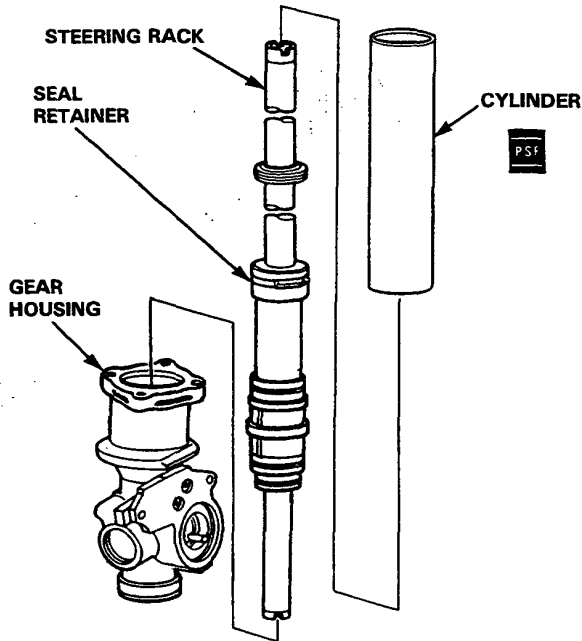

54. Install the cylinder spring and magnet on the steering rack.
55. Grease the special tool and install it on the steering rack.

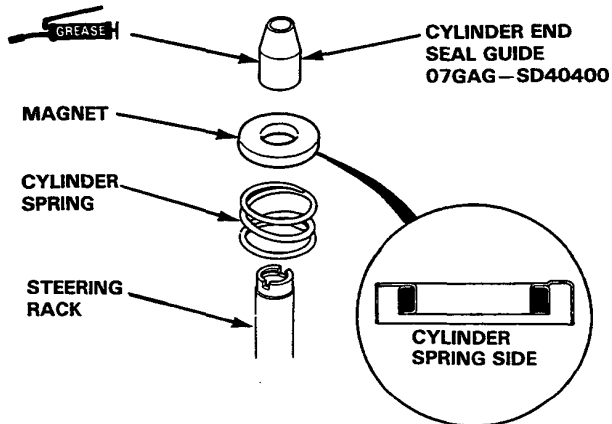

56. Coat the inside surface of the rack bushing retainer with power steering fluid, and install the cylinder end seal and rack bushing A in the retainer.

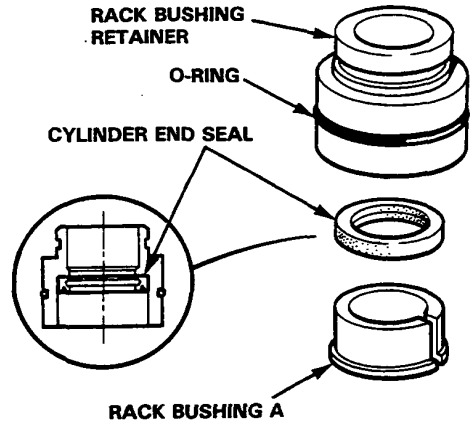

NOTE: Install the cylinder end seal with its grooved side facing rack bushing A.

57. Install the 41 x 2.0 mm O-ring.
58. Coat the outside surface of the rack bushing retainer with power steering fluid, and install it in the front gear housing.
59. Place the flange end of the front gear housing in a vise with soft jaws.

NOTE: Be careful not to damage the housing flange by over-tightening the vise.

60. Tighten the cylinder end screw with the special tool.

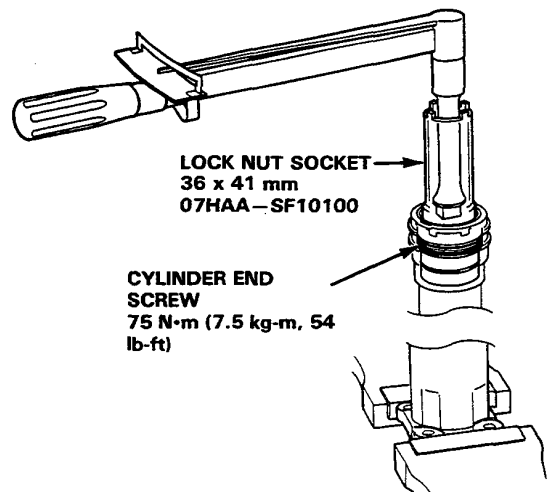

(cont'd)

Steering Gearbox

Overhaul (4WS) (cont'd)

61. Stake the end screw using a hammer and drift as shown.

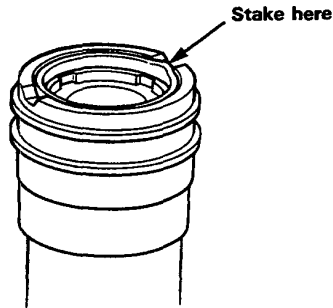

CAUTION: Take care not to damage or crack the front gear housing when staking the end screw.

62. Install the cylinder on the gear housing and temporarily tighten the four cylinder bolts while holding the cylinder against the housing.

CAUTION: Avoid damaging the cylinder end seal.

63. Remove the special tool from the steering rack.

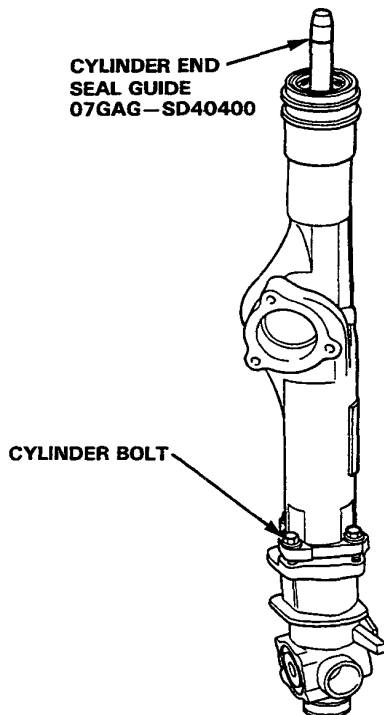

64. Slide the steering rack in the cylinder until the end of the rack projects 63 mm (2.5 in) from the rack bushing retainer.

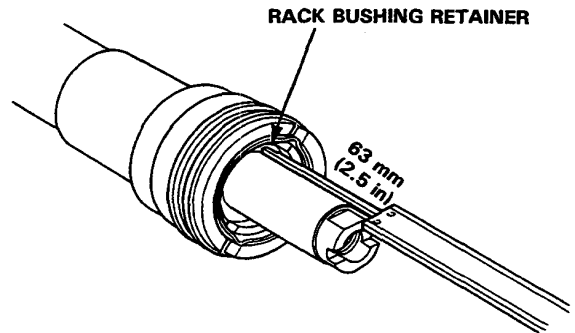

NOTE: The system is in neutral when the rack end projects 63 mm (2.5 in) from the bushing retainer.

65. Tighten the four cylinder housing bolts.

NOTE: Before tightening the bolts, make sure the mating surfaces of the cylinder and gear housing fit properly by pushing them together; hold them together while tightening the bolts.

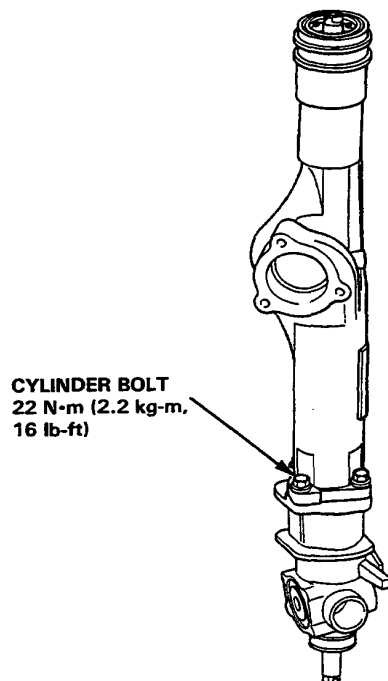



66. Press the steering pinion into the bearing.

NOTE: Install the bearing with its sealed end facing down.

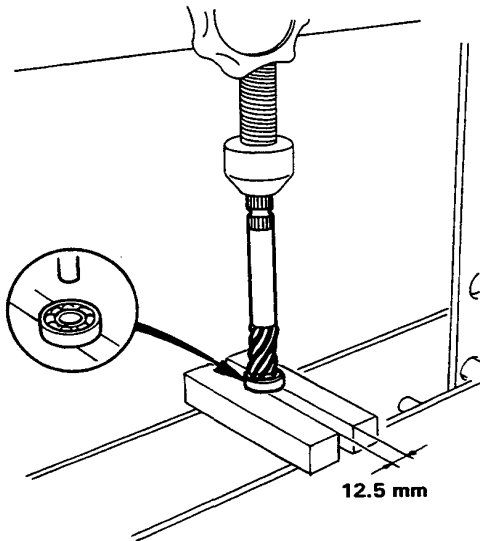

67. Install the 12 mm snap ring on the steering pinion.

68. Pack the bearing cavities with grease, and check for smooth movement.

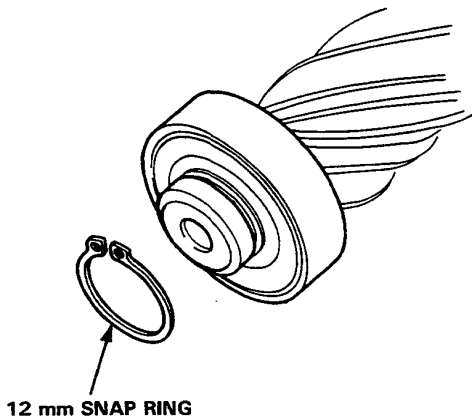

69. Install the steering pinion in the pinion holder.

SOCKET WRENCH
(OD should be less than 27.9 mm/1.10 in)

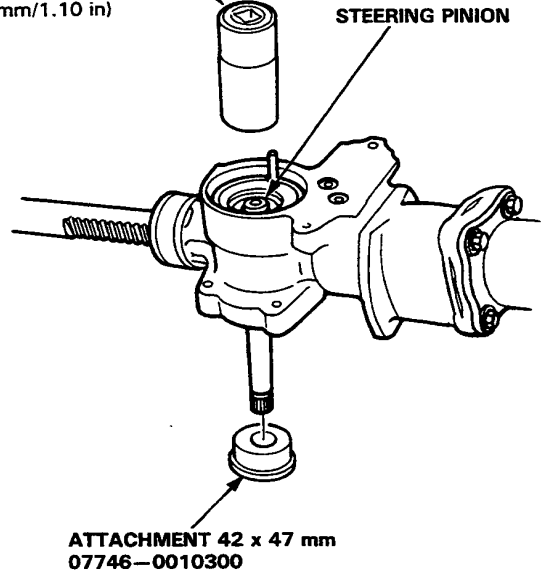

70. Seat the 28 mm snap ring in the groove of the pinion holder.

NOTE: Install the snap ring with its tapered side facing out.

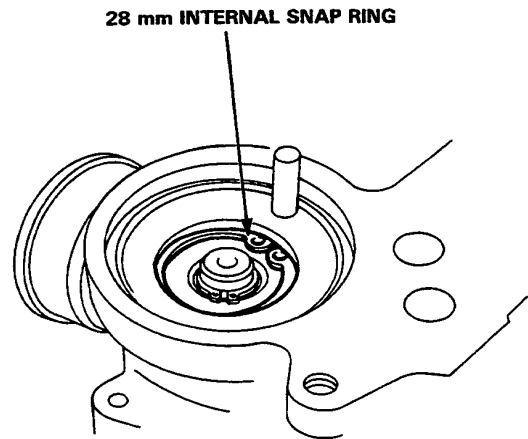

(cont'd)

Steering Gearbox

Overhaul (4WS) (cont'd)

71. Grease the sealing lip of the pinion seal, and install the seal in the gear housing cap using the special tools.

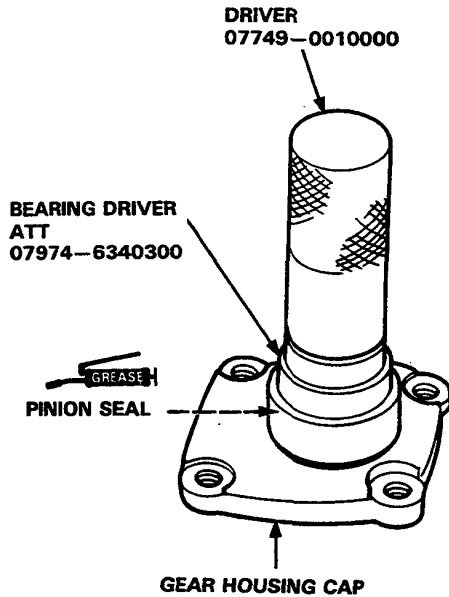

72. Grease the 46 x 1.5 mm O-ring, and install it in the gear housing cap.

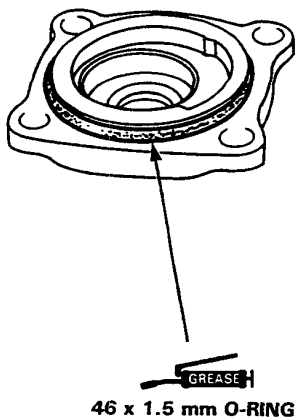

73. Grease the special tool and fit it over the steering pinion.

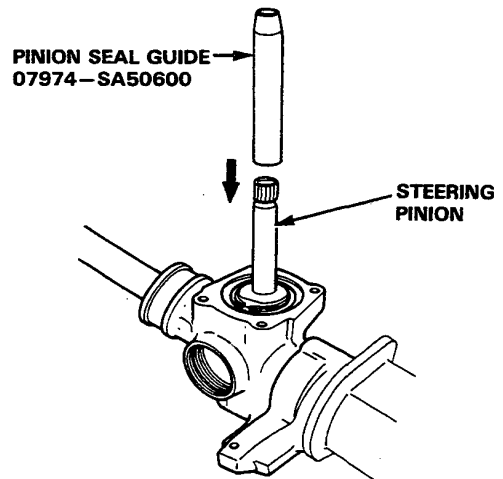

74. Slide the gear housing cap over the steering pinion, being careful not to damage the sealing lip of the pinion seal then remove the special tool.

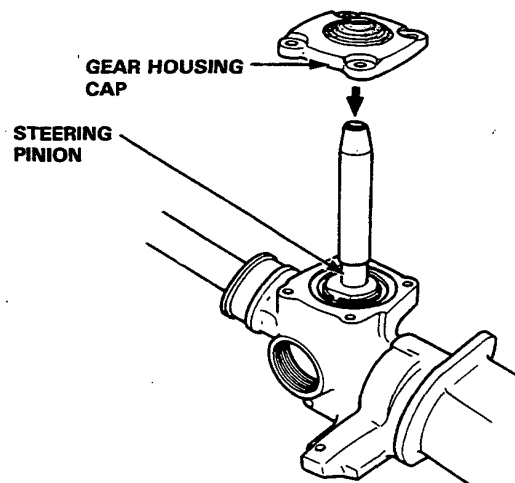



75. Install and tighten the four 6 mm flange bolts.

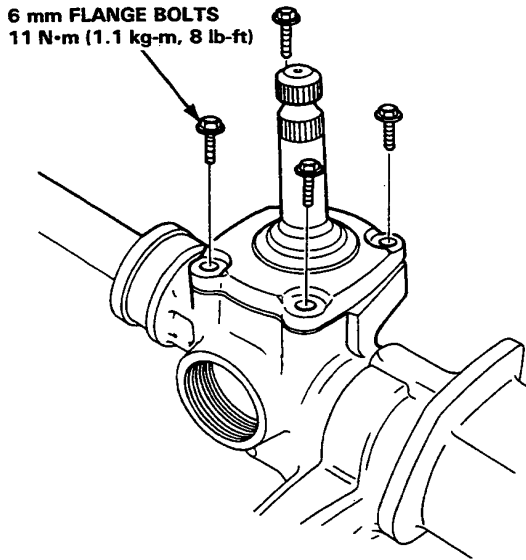

76. Install the control valve unit on the gear housing (page 17-49).

77. Grease the surface of the steering rack guide.

78. Temporarily install the rack guide, rack guide spring and rack guide screw in the gear housing.

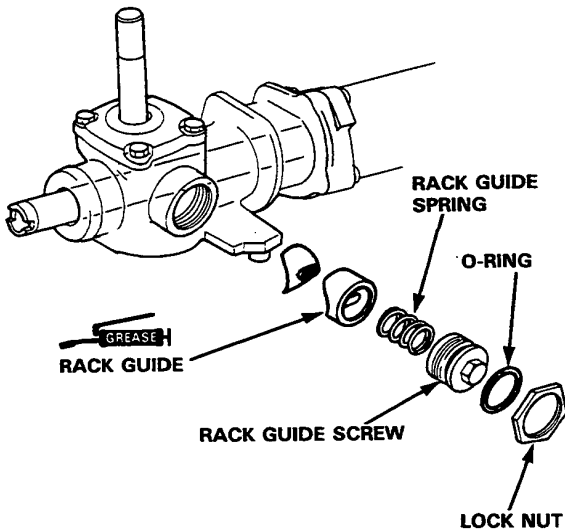

79. Place the driven pinion holder in a vise with soft jaws.

80. Remove the driven pinion screw using the special tool.

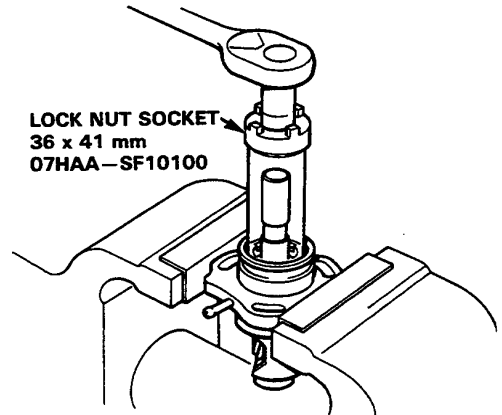

81. Slide the driven pinion out of the pinion holder.

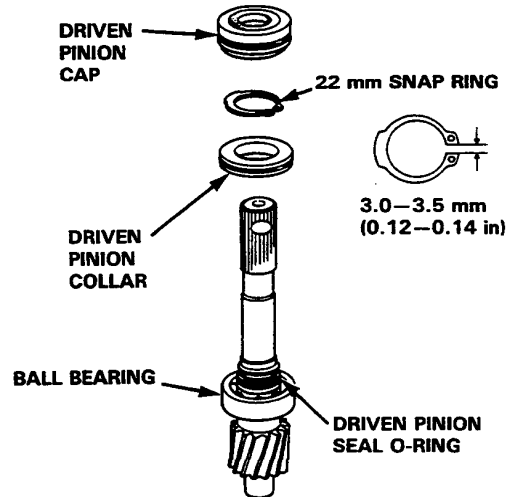

82. Remove the driven pinion cap.

83. Remove the driven pinion collar by removing the 22 mm snap ring.

84. Remove the driven pinion seal O-ring.

85. Check the driven pinion ball bearing for play. If the bearing is noisy or has excessive play, replace the driven pinion.

(cont'd)

Steering Gearbox

Overhaul (4WS) (cont'd)

86. Coat the surface of the special tool with power steering fluid, and slide the 19.8 x 1.9 mm O-ring and driven seal ring over the guide and into the groove.

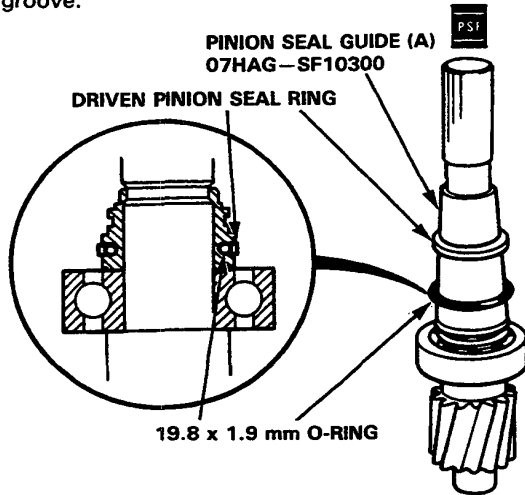

87. Coat the surface of the driven pinion seal ring with power steering fluid.

88. Coat the sliding surface of the special tool with power steering fluid, and place the tool over the pinion seal ring.

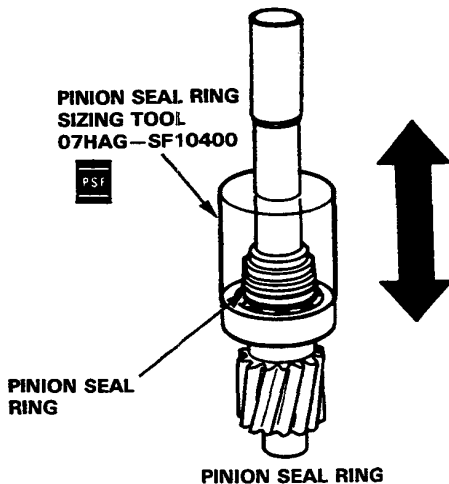

89. Move the sizing tool up and down to seat the driven pinion seal ring.

NOTE: Keep the driven pinion seal ring in the non-tapered part of the tool.

90. Install the 35.5 x 2.4 mm O-ring on the driven pinion collar.

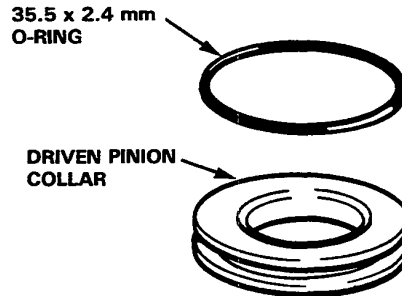

- Coat the surface of the driven pinion seal ring with power steering fluid.

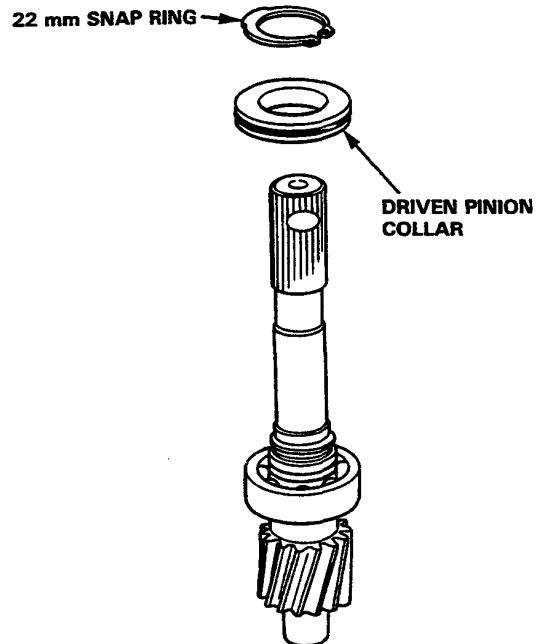

91. Install the driven pinion collar on the driven pinion seal ring, and install the 22 mm snap ring.

92. Check that the driven pinion collar moves freely.



93. Coat the O-ring on the driven pinion collar with power steering fluid, and slide the collar into the pinion holder until it seats against the holder.

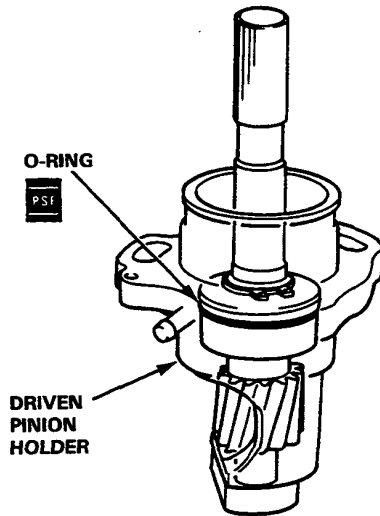

94. Install the driven pinion seal in the driven pinion cap with its sealing lip facing down.

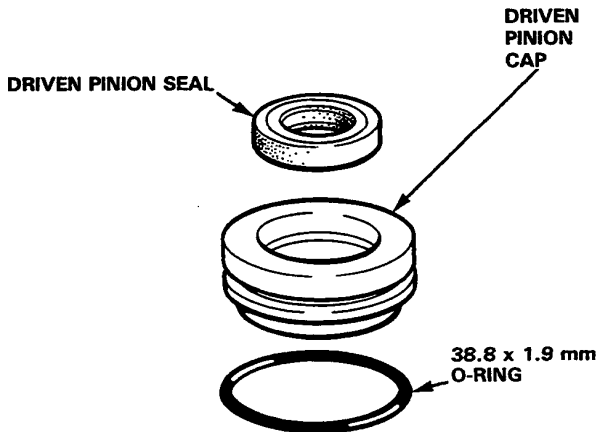

95. Install the 38.8 x 1.9 mm O-ring.

96. Grease the special tool and fit it over the driven pinion shaft.

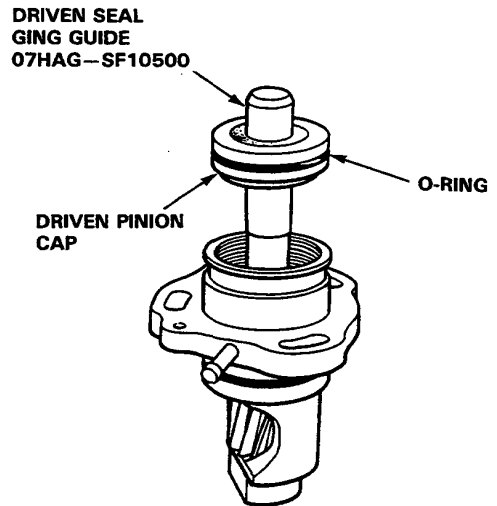

97. Install the driven pinion cap in the driven pinion holder, being careful not to damage the sealing lip of the driven pinion cap seal and O-ring, then remove the special tool.

98. Install the driven pinion cap in the driven pinion holder using the special tool until it bottoms.

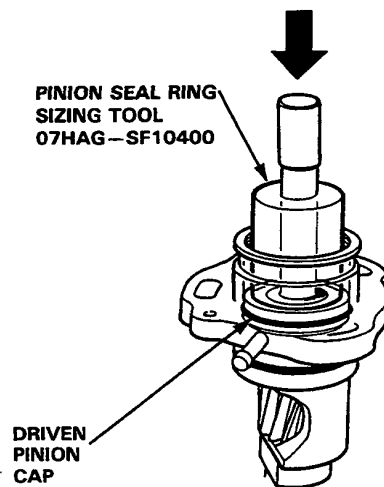

Steering Gear Box

Overhaul (4WS) (cont'd)

99. Place the flange end of the driven pinion holder in a vice with soft jaws.

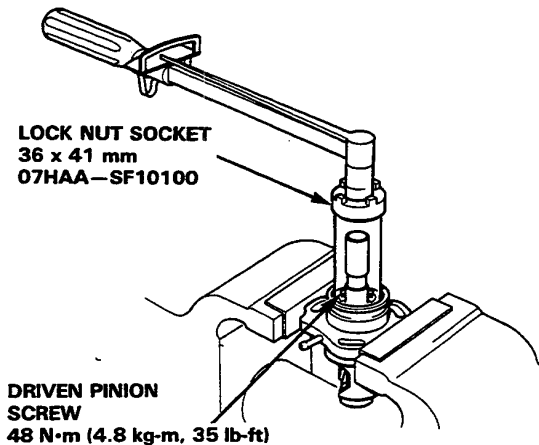

100. Tighten the driven pinion screw using the special tool.
101. When the driven pinion is replaced with new one, stake the driven pinion screw at four places with a punch.

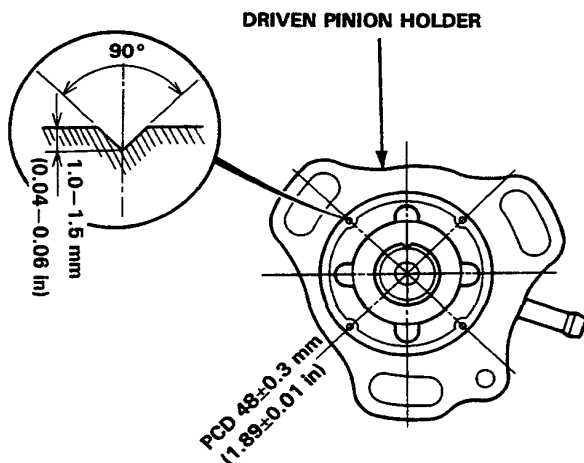

102. Slide the steering rack into the cylinder until the end of the rack is projected 63 mm (2.5 in) from the rack bushing retainer.

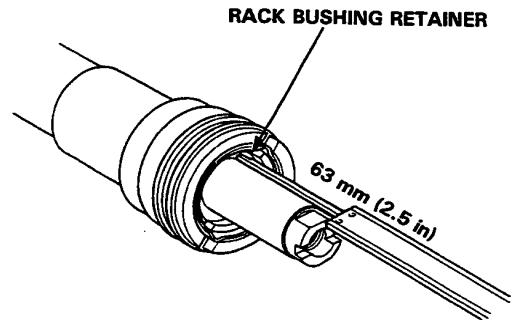

103. Install the 49.5 x 2.0 mm O-ring in the driven pinion holder.
104. Coat the surface of the O-ring with power steering fluid.

RH Drive:

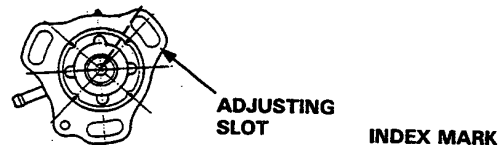

LH Drive:

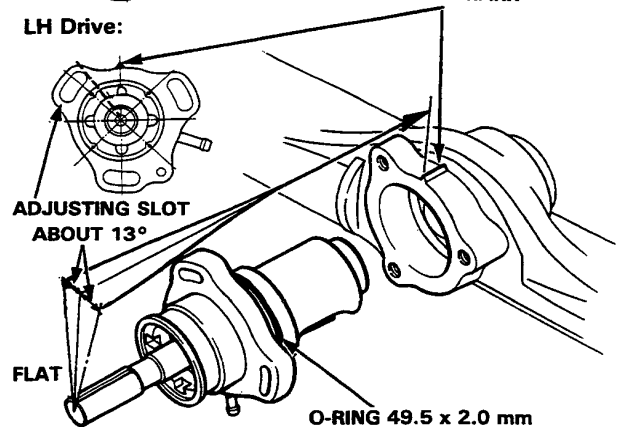

105. Install the pinion holder on the gear housing aligning the mark on the housing with the flat on the pinion shaft.

NOTE: Before installing, position the shaft flat about 13° to the left (LH Drive) or right (RH Drive) of the aligning mark (even with the end of the nearest adjusting slot). This will align the flat with the mark as the holder is inserted fully.



106. Install the driven holder washer with the mark on the same axis as the steering rack. Loosely install the driven pinion holder bolts using a TORX® T40 bit.

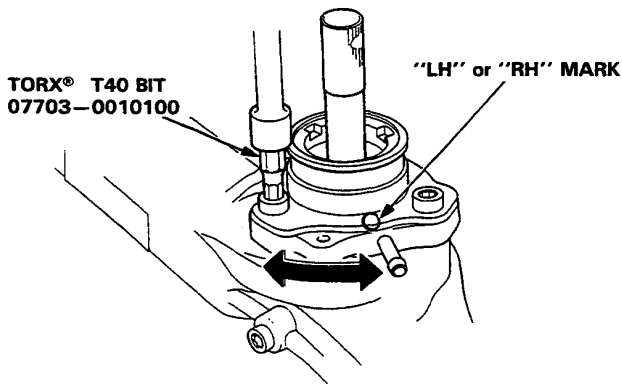

107. Tighten the rack guide screw until it compresses the spring and seats against the rack guide, then loosen it. Retighten it to 4 N·m (0.4 kg·m, 3 lb·ft), back it off about 30°–40°, and install the lock nut. Tighten the lock nut while holding the rack guide screw with the special tool.

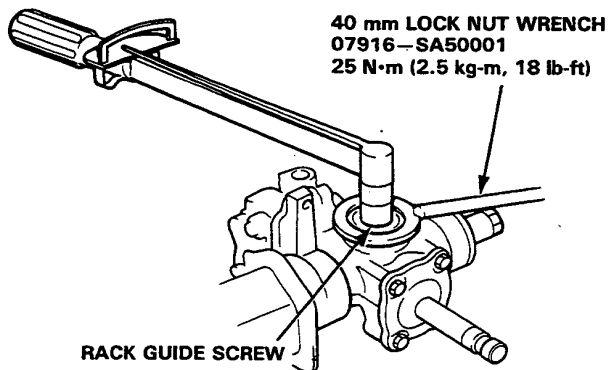

108. Turn the driven pinion holder:

LH Drive: clockwise

RH Drive: counterclockwise

RH Drive

LH Drive

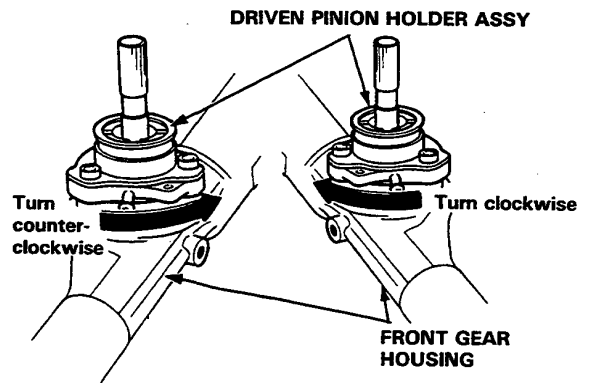

109. Remove the driven plug bolt and install the special tool "Dial Indicator Holder" on the front gear housing B.

110. Remove the existing spindle from the dial indicator and install 30 mm extension; then insert the dial indicator into the holder and secure with the lock screw.

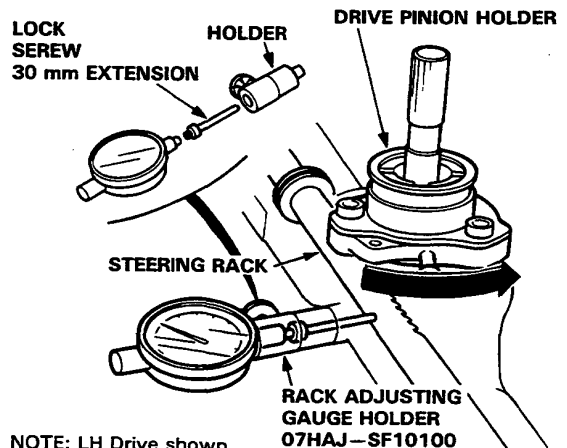

NOTE: LH Drive shown, RH Drive is symenety.

111. Turn counterclockwise: LH Drive, or clockwise: RH Drive slowly until the steering rack is preloaded the proper amount.

STANDARD: 0.10–0.20 mm (0.004–0.008 in)

112. Remove the dial indicator and holder.

(cont'd)

Steering Gear Box

Overhaul (4WS) (cont'd)

113. Tighten the driven holder bolts using a TORX® T40 bit.

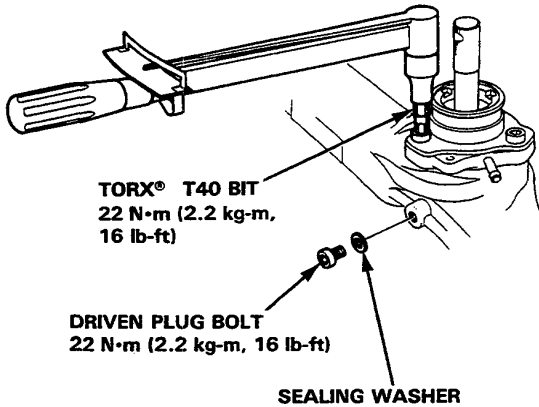

114. Tighten the driven pinion plug bolt with the sealing washer.

115. Grease the special tool and fit it the driven pinion.

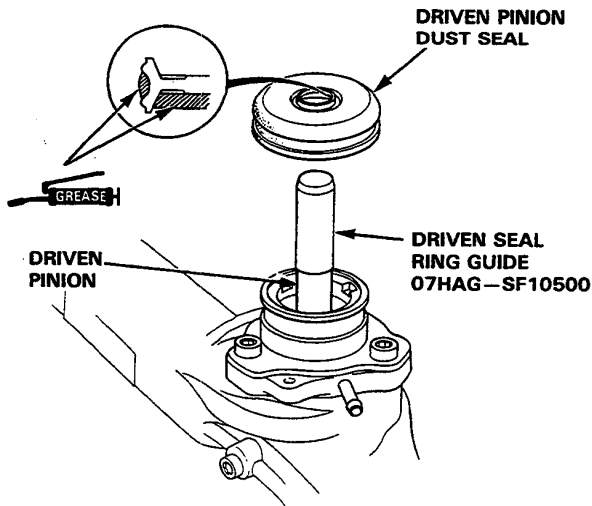

116. Pack the sealing lip of the driven pinion dust seal with grease, and install it in the driven holder. then remove the special tool.

117. Install the dust cover; tighten the dust cover band screw.

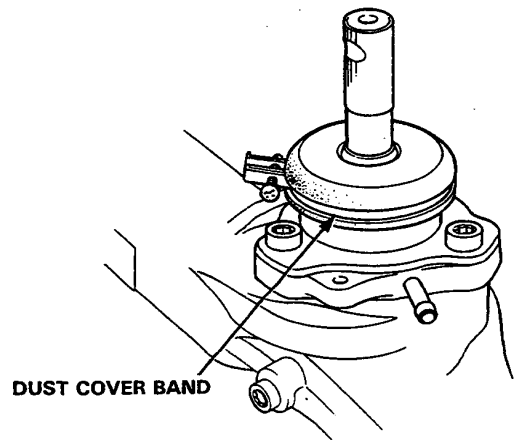
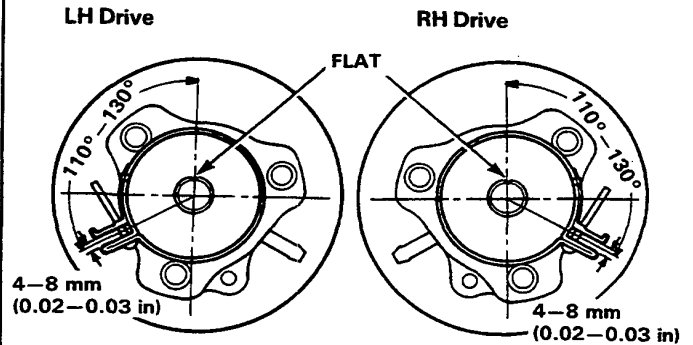



118. Screw each tie-rod into the rack with the stopper and lock washer while holding the lock washer so its tabs are in the slots in the end of the rack.

Tighten the tie-rod securely, then bend the lock washer back against the flat on the flange as shown.

Install the boots and secure with the boot band and tube clamp.

After assembling, slide the rack right and left to be certain that the boots are not deformed or twisted.

119. Install the air transfer tube with clips as shown.

NOTE: LH Drive shown, RH Drive is symmetrically.

