

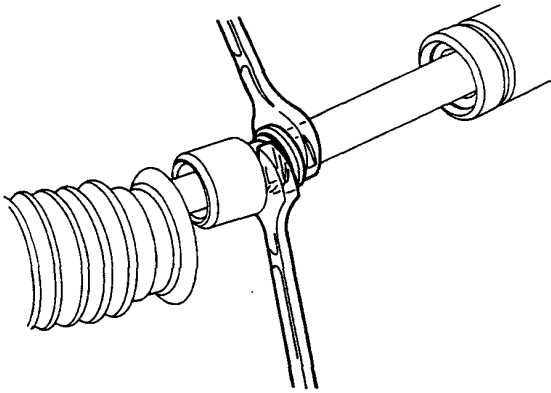

## Overhaul (2WS)

1. Remove the control unit as described on page 11-36.
2. Carefully clamp the gearbox in a vise with soft jaws.
3. Loosen the bands, pull the boots away from the ends of the gearbox, and straighten the tie-rod lock washers.



4. Push the right end of the rack back into the cylinder housing so the smooth surface that rides against the seal won't be damaged.

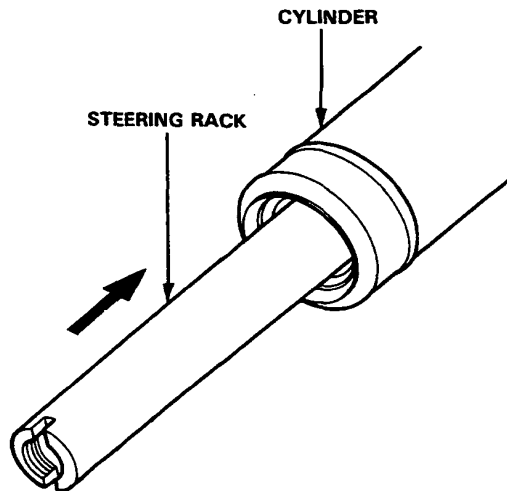

5. Loosen the rack screw lock nut, and remove the rack guide screw.

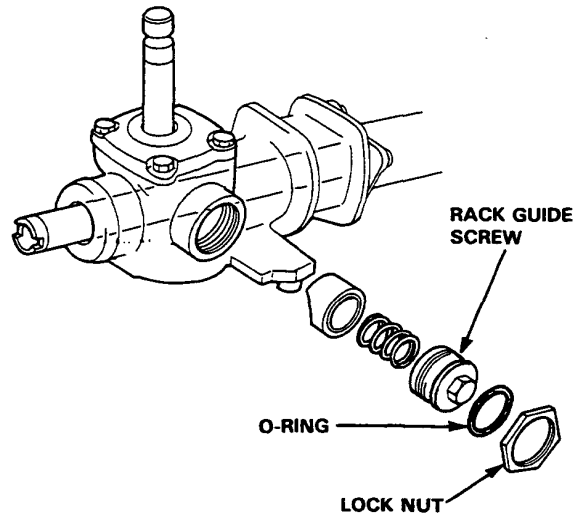

6. Remove the 28 mm snap ring from the bottom of the gear housing.

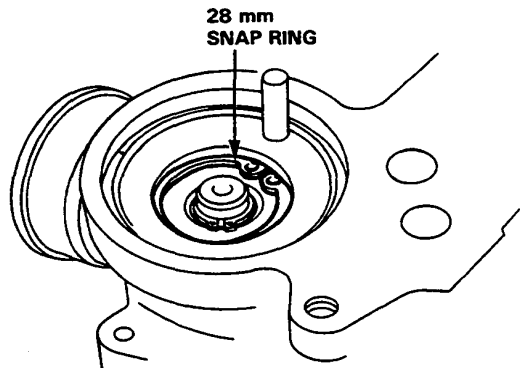

(cont'd)

# Steering Gearbox

## Overhaul (2WS) (cont'd)

7. Remove the pinion from the gear housing by tapping it lightly.

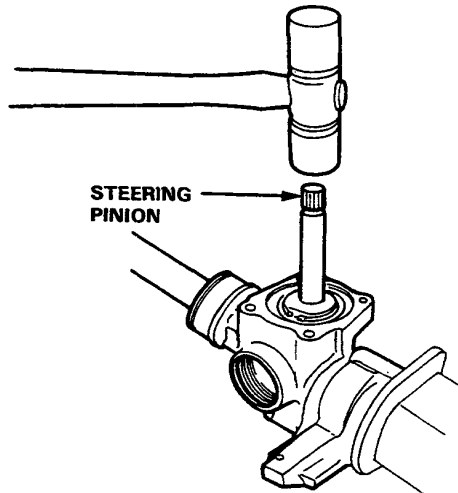

8. Check the pinion lower ball bearing for play.

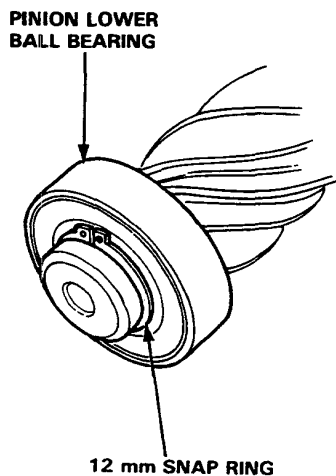

9. If the bearing is noisy or has excessive play, remove the 12 mm snap ring and remove the bearing using a commercially available bearing puller.

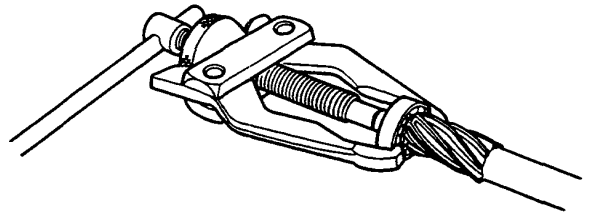

10. Remove the four bolts from the end of cylinder housing, then slide the housing off the rack.

11. Remove the cylinder housing.

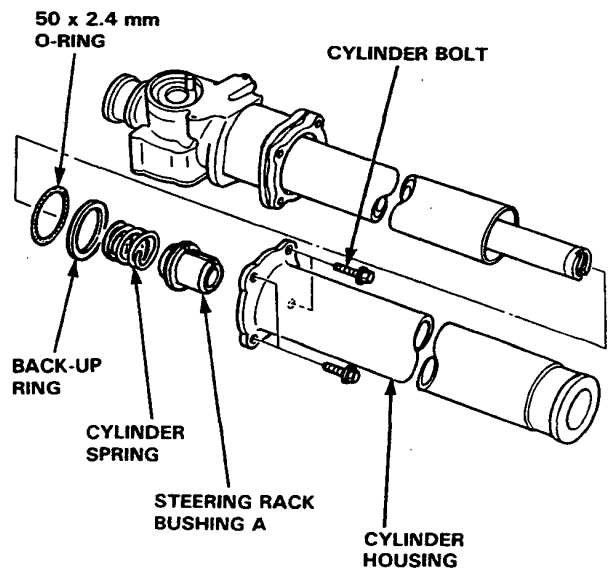

12. Remove the O-ring, back-up ring, steering rack bushing A and cylinder spring.



13. Remove the cylinder end seal from the cylinder housing.  
Use your fingers or a wooden stick to avoid damaging the housing.

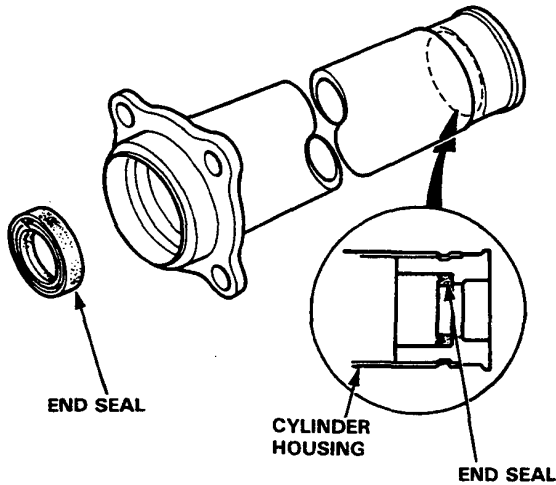

14. Remove the cylinder, cylinder seal retainer, cylinder cap and steering rack from the gear housing.

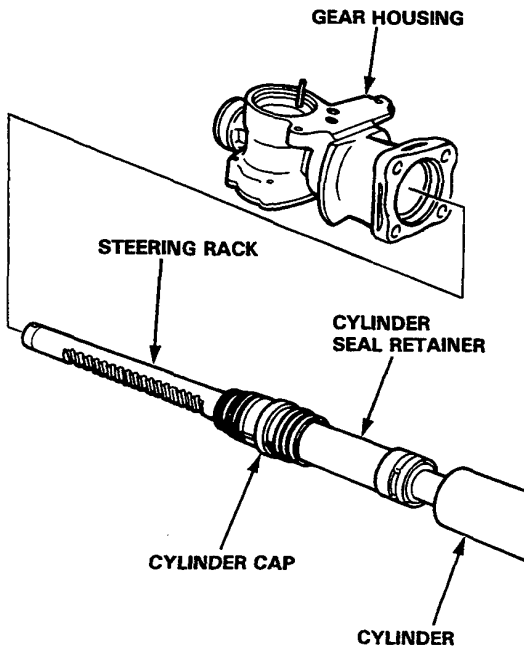

15. Remove the retainer washer from the gear housing.

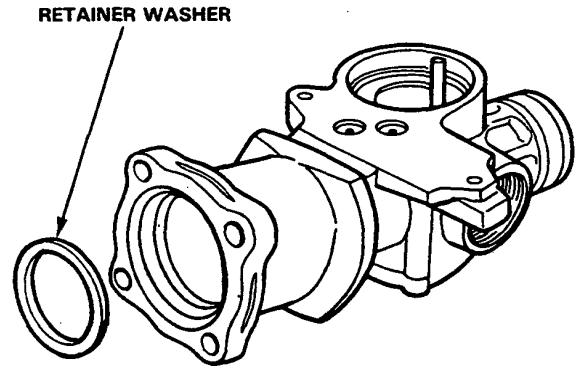

16. Remove the gear housing cap from the gear housing by removing the four 6 mm flange bolts.

17. Remove the steering pinion seal from the gear housing cap.

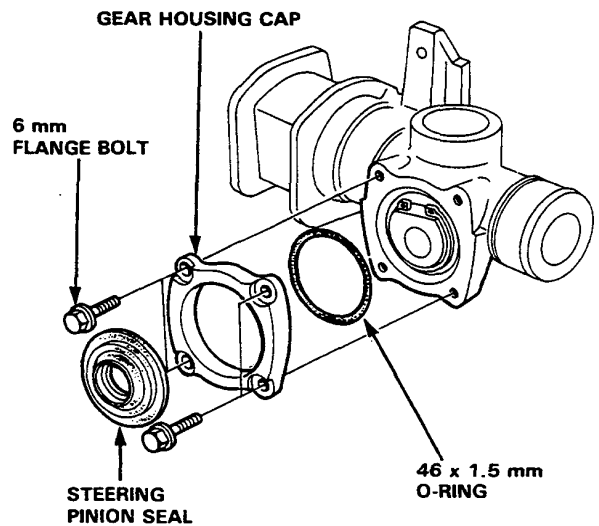

18. Remove the O-ring from the gear housing.

(cont'd)

# Steering Gearbox

## Overhaul (2WS) (cont'd)

19. Check the upper bearing for faulty movement and excessive play; if it is good and the grease in it is clean, go on step 20.

If it is damaged, or if dirt has gone past the seal into the grease, replace the bearing.

- Remove the 30 mm snap ring from the pinion holder.

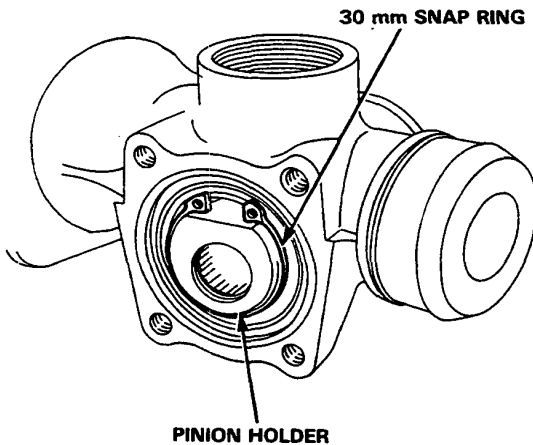

- Remove the pinion holder from the gear housing.

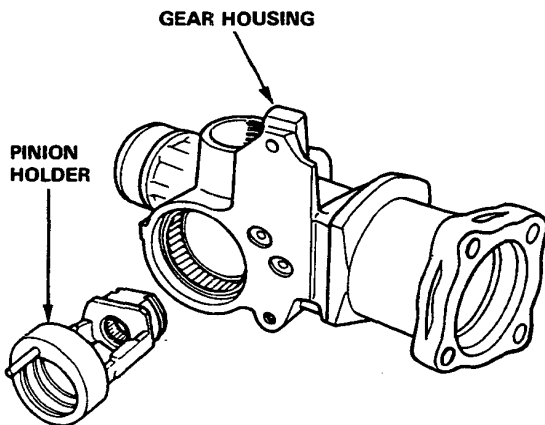

- Remove the pinion upper ball bearing from the gear housing.

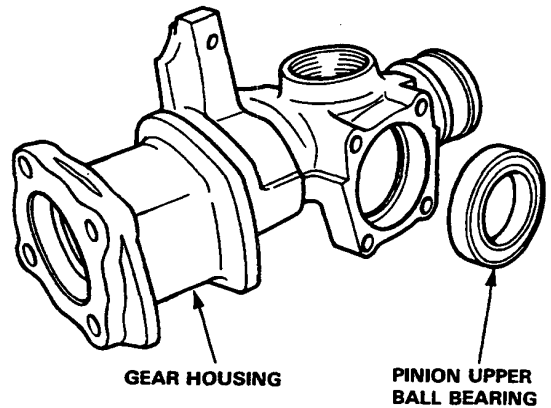

- Check the needle roller bearings in the pinion holder and in the gear housing for damage; if they are OK, pack them with grease. If the bearings are damaged, replace them as a set.

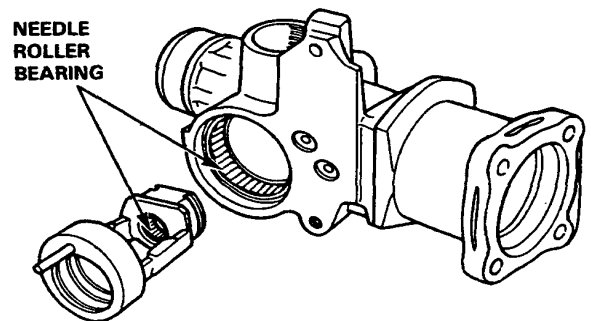



- Pack a new upper bearing with grease, then drive the bearing into the gear housing with its sealed side facing out.

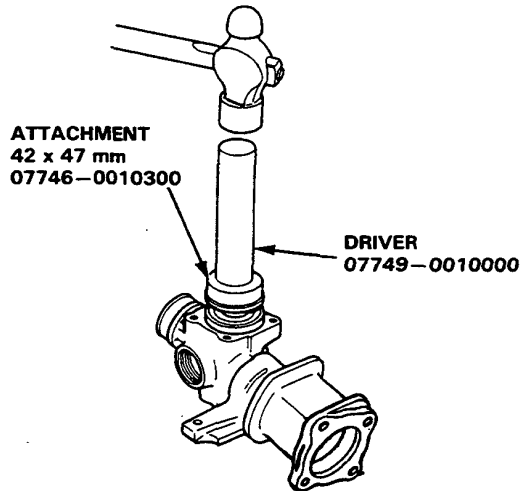

- Install the pinion holder in the gear housing.

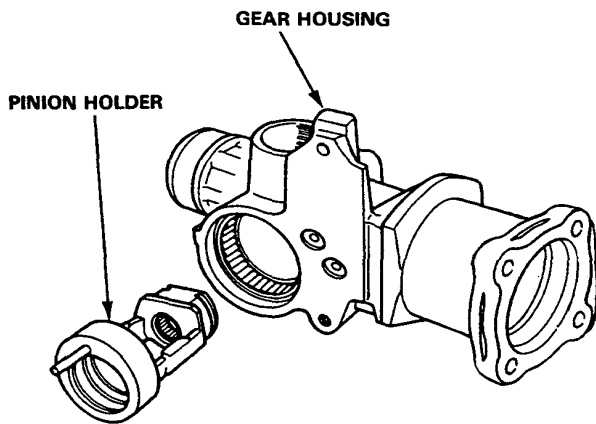

- Reinstall the 30 mm snap ring with its tapered side facing out.

NOTE: Snap ring ends must be aligned with the flat area.

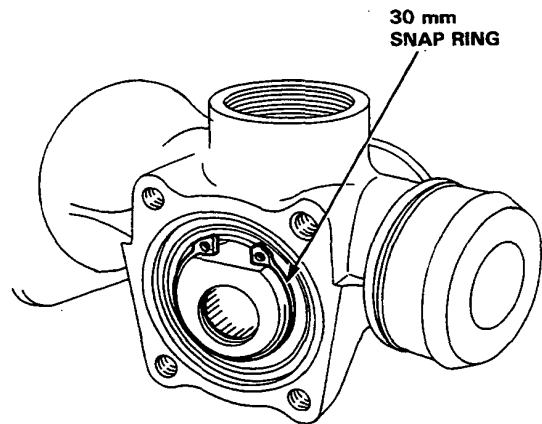

20. Remove the cylinder and seal retainer from the steering rack.

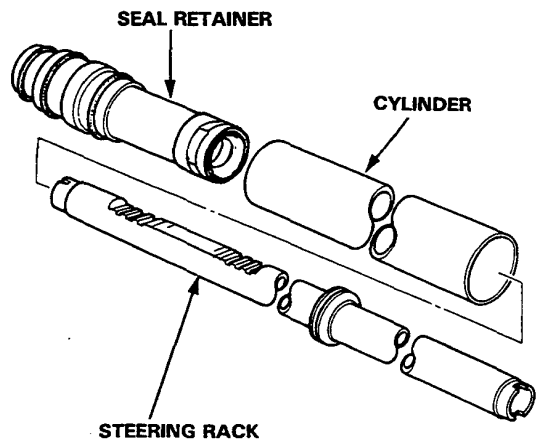

# Steering Gearbox

## Overhaul (2WS) (cont'd)

21. Remove the O-ring and circlip from the seal retainer, then remove the cylinder cap from the seal retainer.
22. Remove the O-rings from the cylinder cap.

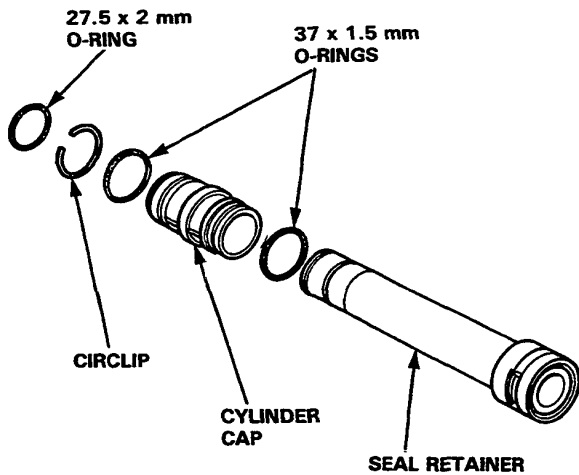

23. Remove the bushing stopper ring from the seal retainer.
24. Remove the cylinder end seal.

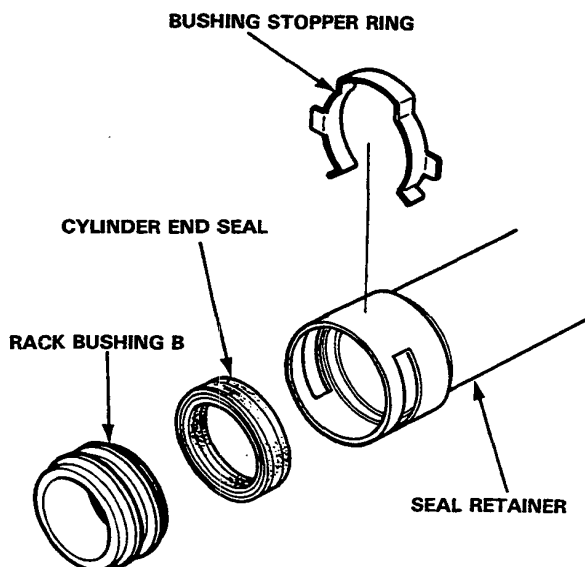

25. Carefully pry the piston seal ring and O-ring off the rack.

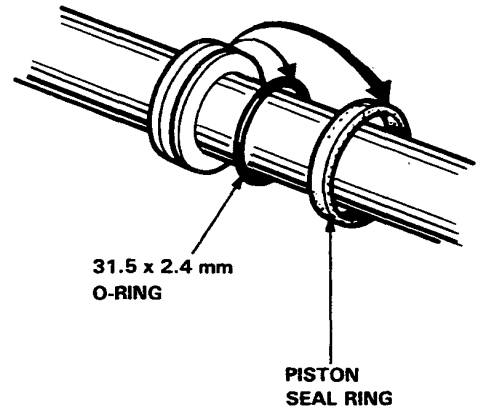

**NOTE:** Before reassembling any parts, inspect them as described on page 11-23, and make sure they are clean. Replace worn or damaged parts.

26. Install a new O-ring on the rack with its narrow edge facing out.

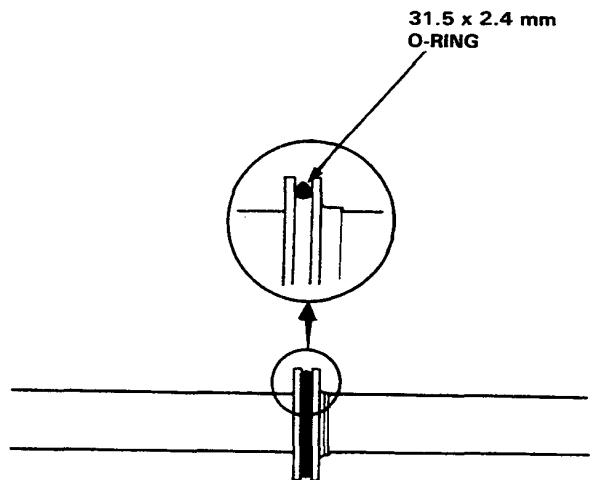



27. Coat the pinion seal ring guide with power steering fluid, and slide it onto the rack, big end first.
28. Position the new piston seal ring on the guide tool, slide it down to the big end of the tool, and then pull it off into the piston groove on top of the O-ring.

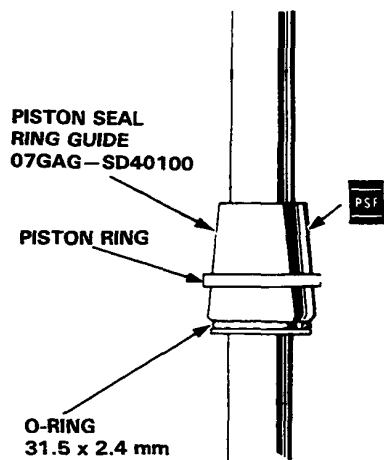

29. Coat the piston seal ring and inside of the sizing tool with power steering fluid. Carefully slide the tool onto the rack and over the piston ring, then rotate the tool as you move it up and down to seat the piston ring.

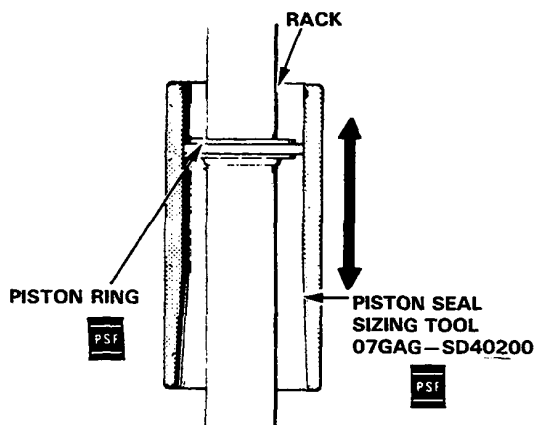

30. Coat new O-rings with grease and install them on the cylinder cap.

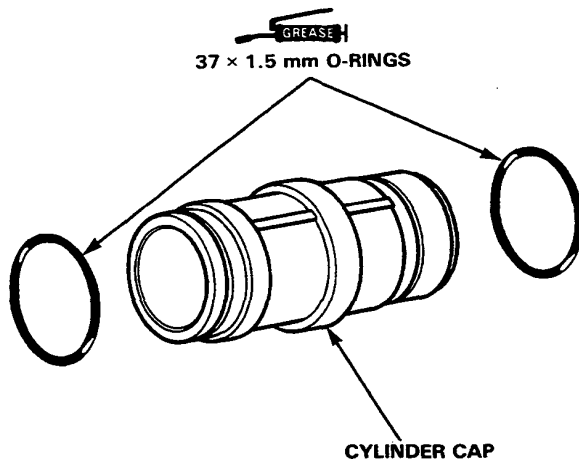

31. Slide the cylinder cap onto the seal retainer.
32. Install the circlip and O-ring on the seal retainer.

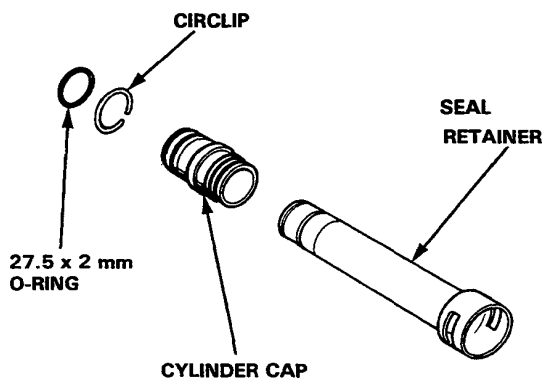

(cont'd)

# Steering Gearbox

## Overhaul (2WS) (cont'd)

33. Grease the sliding surface of the steering rack bushing B, and install the bushing on the steering rack with the groove of the bushing facing the steering rack piston.

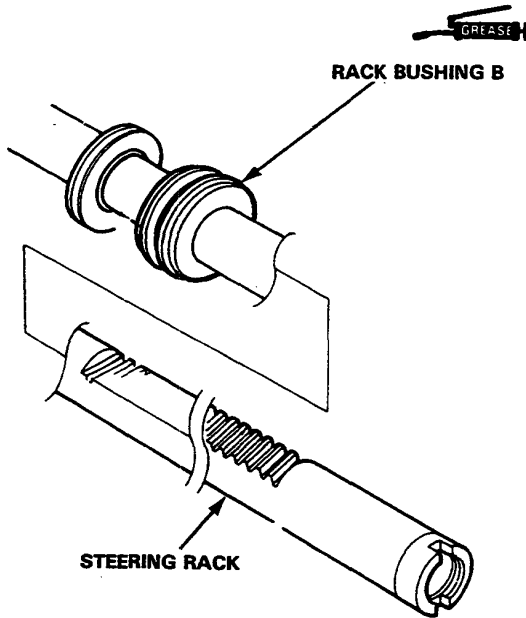

34. Grease the sliding surfaces of the new cylinder end seal and cylinder end seal slider, then set the seal on the seal slider with its grooved side facing opposite the slider.

Install end seal with its grooved side facing opposite side slider.

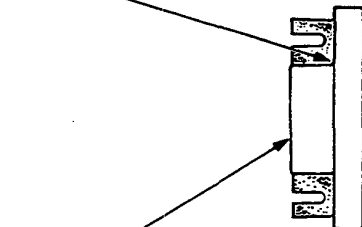

CYLINDER END SEAL SLIDER  
07GAG-SD40300

35. Grease the steering rack, and install the cylinder end seal.

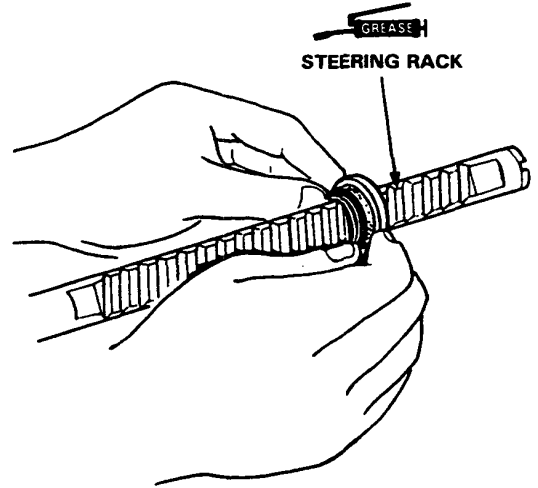

36. Remove the guide tool from the cylinder end seal, then separate the ends of the tool and remove it from the rack.

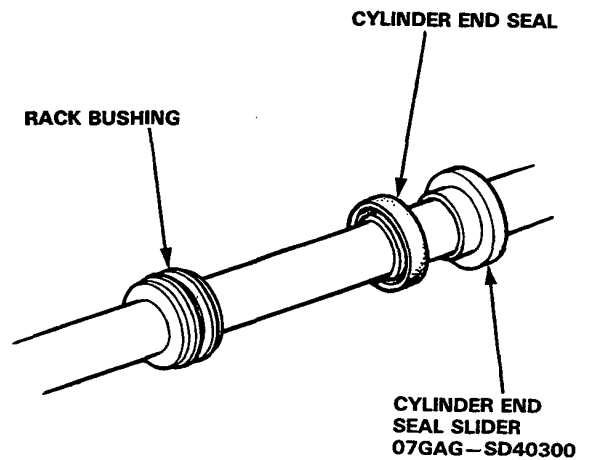



37. Fit the seal retainer on the steering rack.

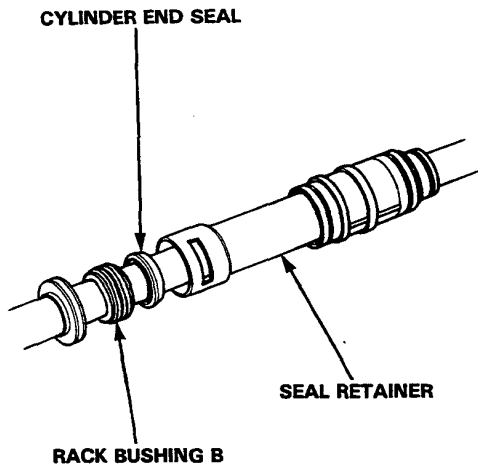

38. Push the rack bushing B toward the seal retainer by hand until the cylinder end seal seated in the retainer. Fit the seal stopper ring in the groove of the seal retainer securely.

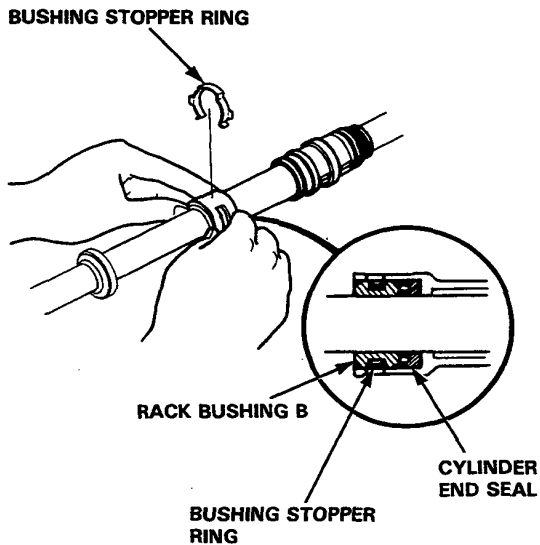

39. Install the retainer washer on the gear housing.

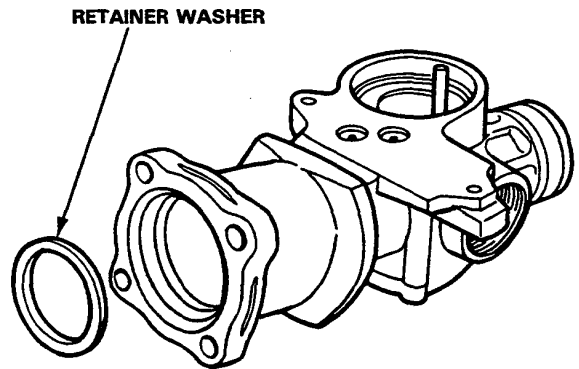

40. Place the gear housing on the work bench and insert the seal retainer and steering rack into the gear housing.

41. Coat the inside of the cylinder with power steering fluid, slide it over the rack and into the gear housing; press it into the housing until it seats.

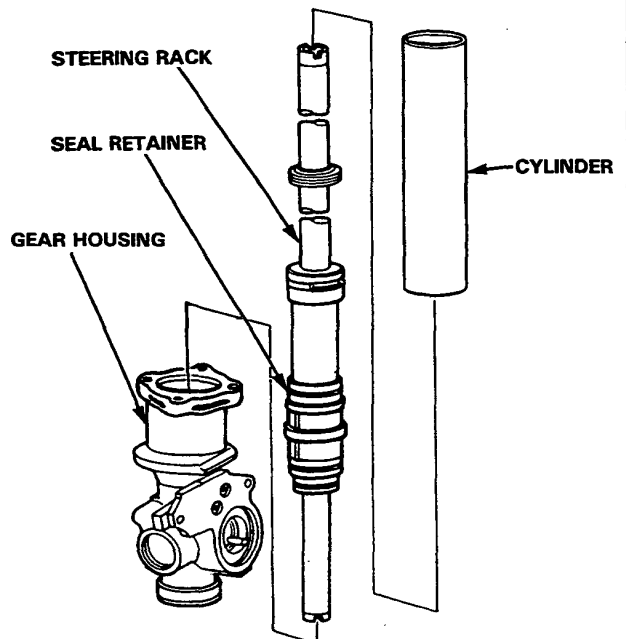

(cont'd)

# Steering Gearbox

## Overhaul (2WS) (cont'd)

42. Install the cylinder spring over the rack, then coat the rack bushing A with power steering fluid and install it on the spring.
43. Grease the end guide and slip it onto the end of the steering rack.

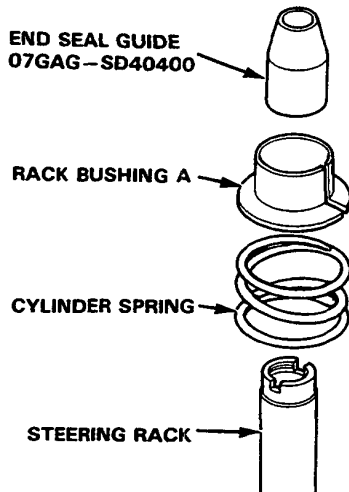

44. Coat the inside surface of the cylinder with power steering fluid and install the cylinder end seal with its groove side facing out.

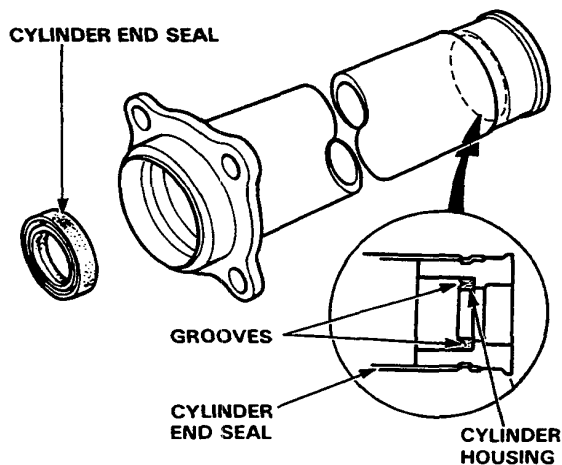

45. Install the O-ring and back-up ring on the gear housing.

46. Carefully install the cylinder on the gear housing and loosely install with four bolts.

**CAUTION:** Be careful not to damage the end seal in the cylinder housing.

47. Remove the end seal guide from the steering rack.

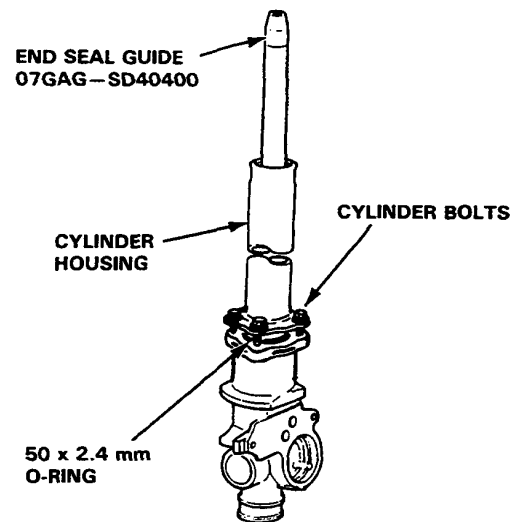

48. Insert the steering rack into the cylinder housing being careful not to damage the steering rack sliding surface.

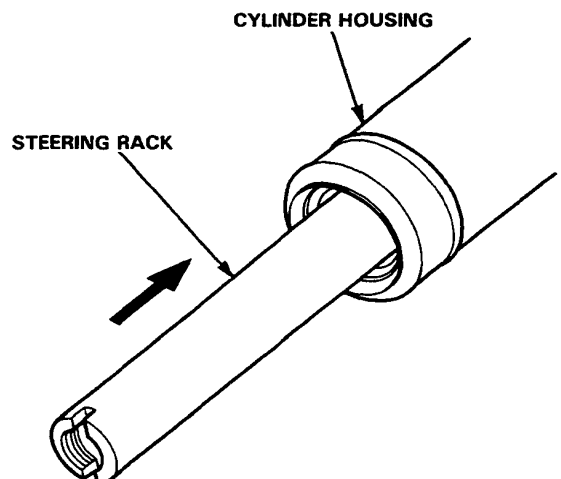



49. Tighten the cylinder housing to the gear housing with four bolts.

NOTE: Before tightening the bolts, make sure the mating surfaces of the cylinder and gear housings fit properly by pushing them together; hold them together while tightening the bolts.

**CYLINDER BOLT**  
22 N·m  
(2.2 kg-m, 16 lb-ft)

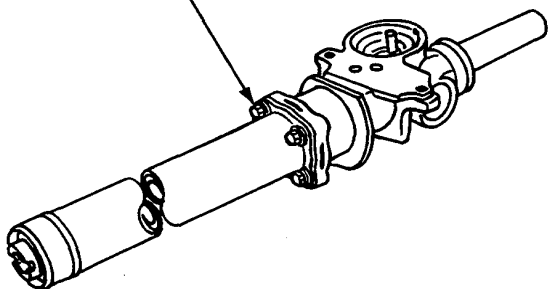

50. Press the lower ball bearing onto the pinion with its shielded side facing down.

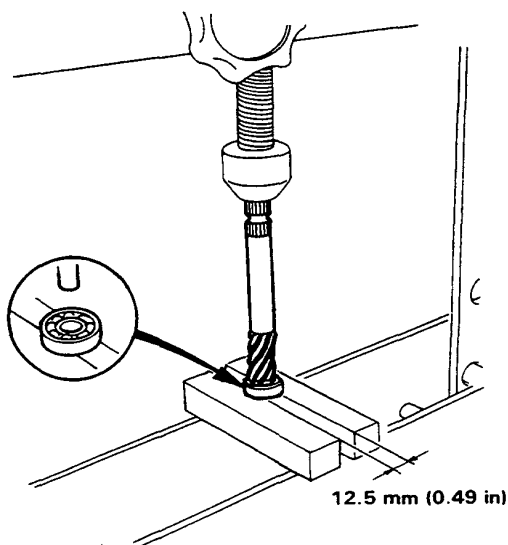

51. Install the 12 mm snap ring on the steering pinion.

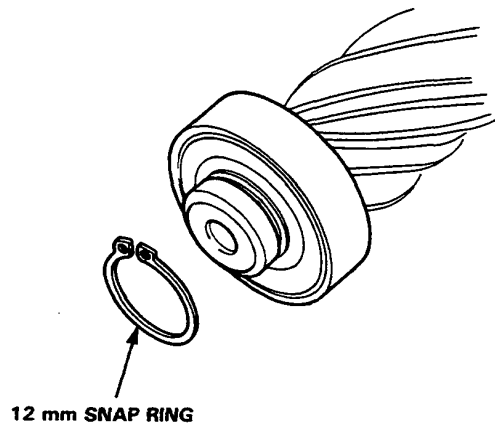

52. Install the steering pinion in the pinion holder.

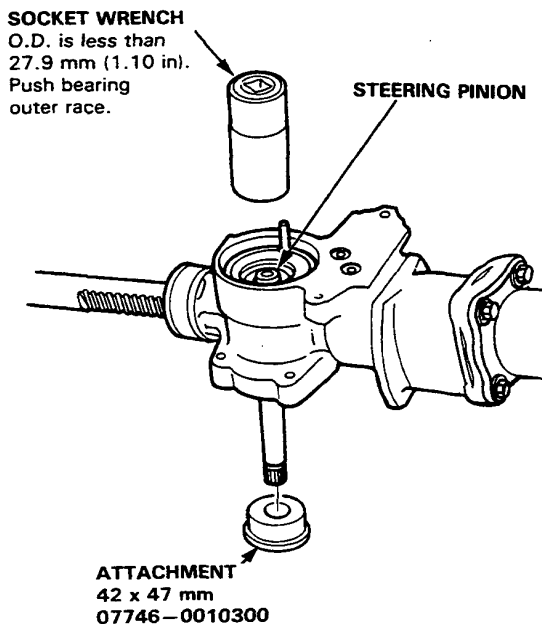

(cont'd)

# Steering Gearbox

## Overhaul (2WS) (cont'd)

53. Install the 28 mm snap ring securely in the pinion holder groove.

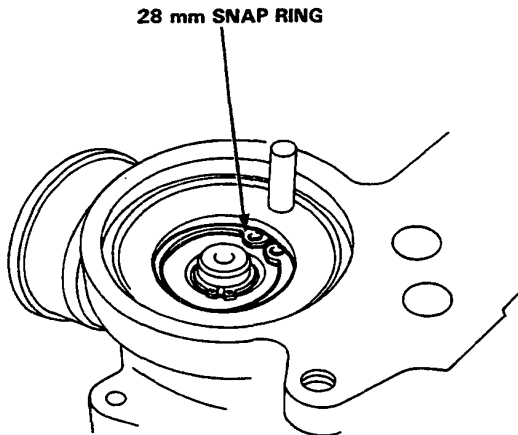

54. Grease the steering pinion seal, and install it on the gear housing using the special tools.

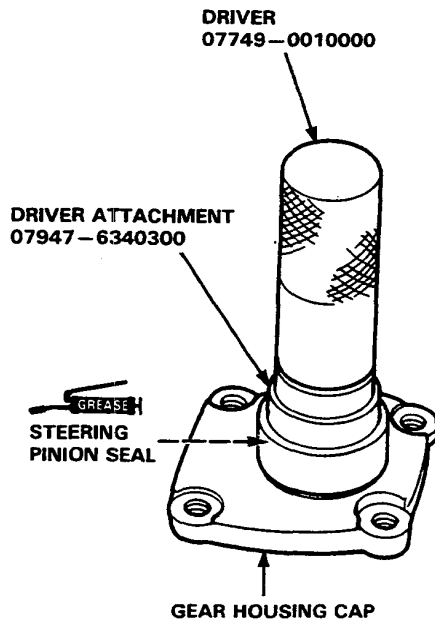

55. Grease the new O-ring and install it in the groove in the gear housing cap.

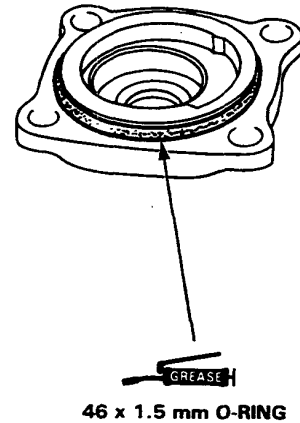

56. Grease the special tool and fit it over the steering pinion.

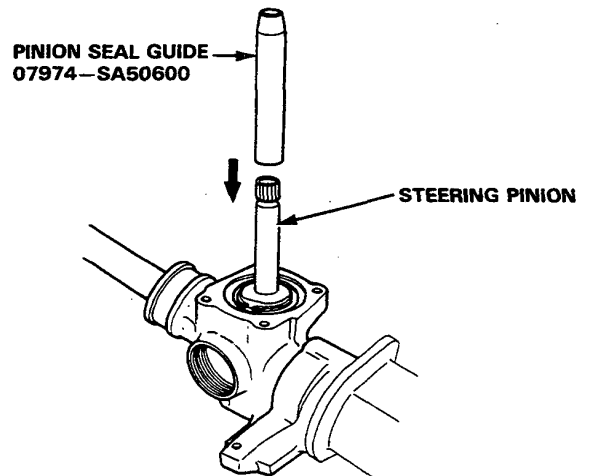



57. Install the gear housing cap being careful not to damage or distort the lip of the seal, or dislodge the seal spring.

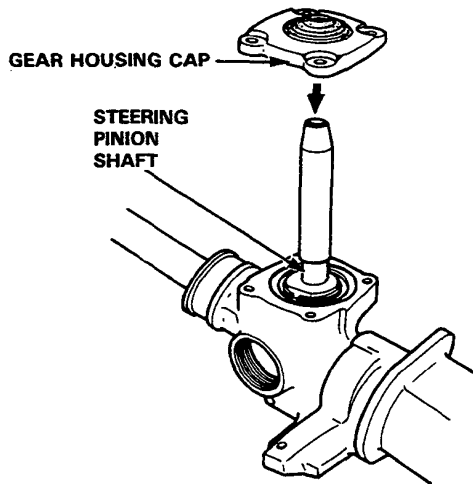

58. Remove the special tool.

59. Tighten the four gear housing cap bolts.

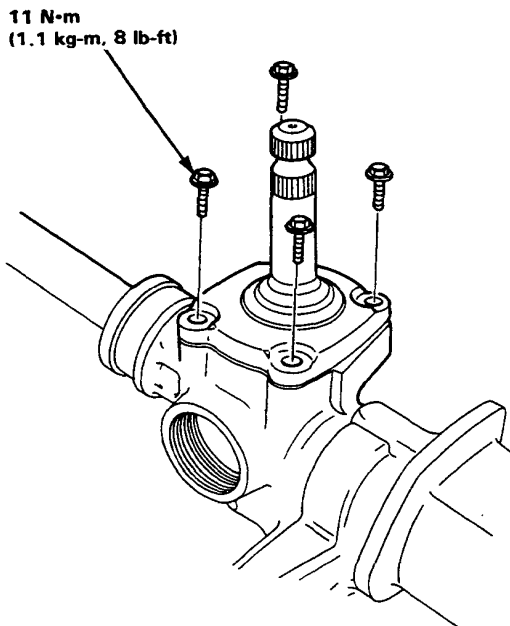

60. Install the control valve unit on the gear housing.

61. Coat the rack guide with grease.

62. Install the rack guide, spring and rack guide screw on the gear housing.

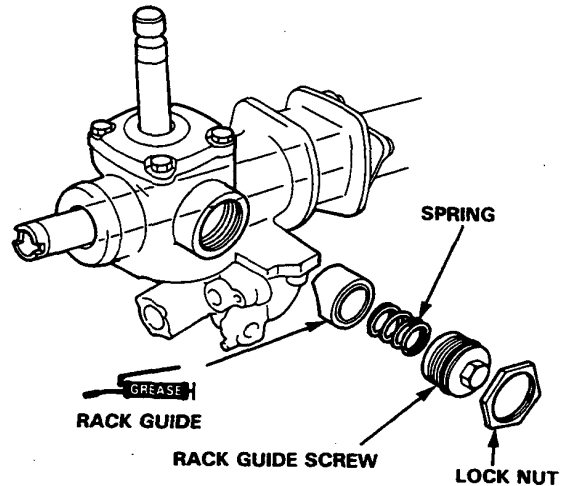

63. Tighten the rack guide screw until it compresses the spring and seats against the rack guide, then loosen it.

Retighten it to 3 N·m (0.3 kg·m, 2 lb-ft), back off about 20°–30° and install the lock nut on the rack guide screw.

64. Tighten the lock nut while holding the rack guide screw with the lock nut wrench.

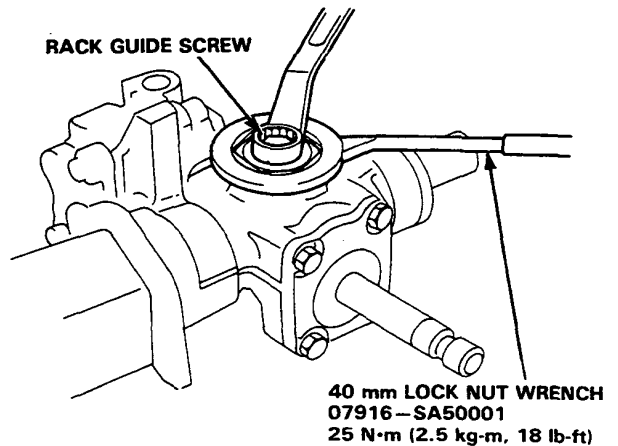

(cont'd)

# Steering Gearbox

## Overhaul (2WS) (cont'd)

65. Screw each tie-rod into the rack while holding the lock washer so its tabs are in the slots in the rack end.

NOTE: Install the stopper washer with the chamfered side facing out.

66. Tighten the tie-rod securely, then bend the lock washer back against the flat on the flange as shown.

67. Install the boots and secure with boot band and tube clamp.

68. Install the air transfer hose and clamp with transfer clips as shown.

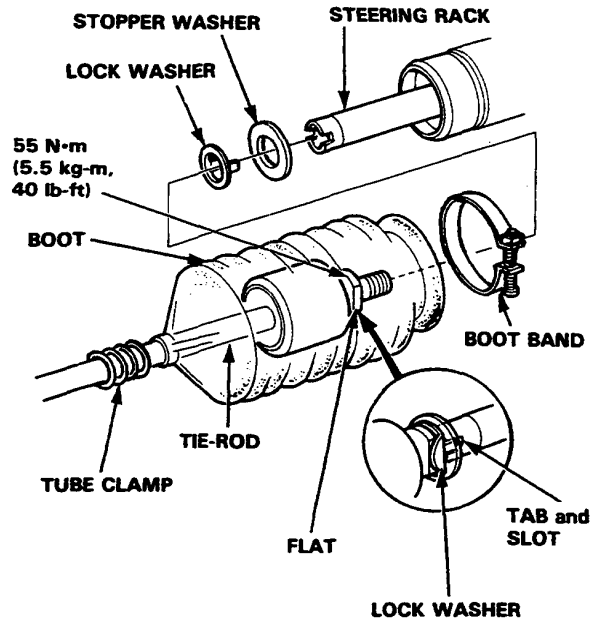

LH Drive:

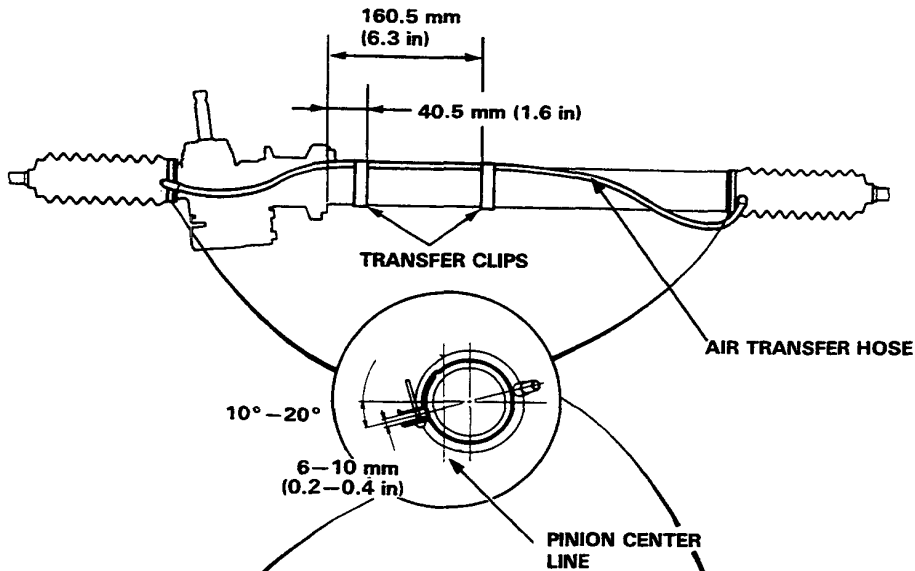

RH Drive:

