

Steering Gearbox

Valve Body Unit Overhaul

Removal:

1. Drain the power steering fluid (page 11-19).
2. Remove the gearbox shield.
3. Using solvent and a brush, wash any oil and dirt off the control unit, its lines, and that end of the gearbox. Blow dry with compressed air.
4. Using flare nut wrenches, disconnect the four lines from the control unit.

To reservoir tank
12 mm wrench

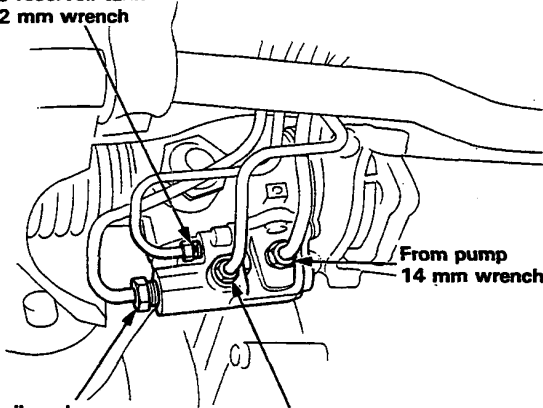

To oil cooler
17 mm wrench

To speed sensor
12 mm wrench

5. Remove the two 6 mm flange bolts and remove the valve body unit from the gear box.

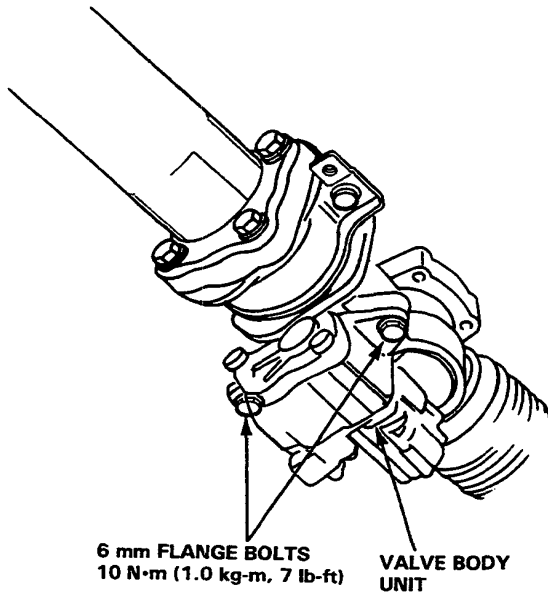

Disassembly:

6. Remove the O-rings and port orifices from the gear box.
7. Remove the O-ring from the valve body unit.

PORT ORIFICES

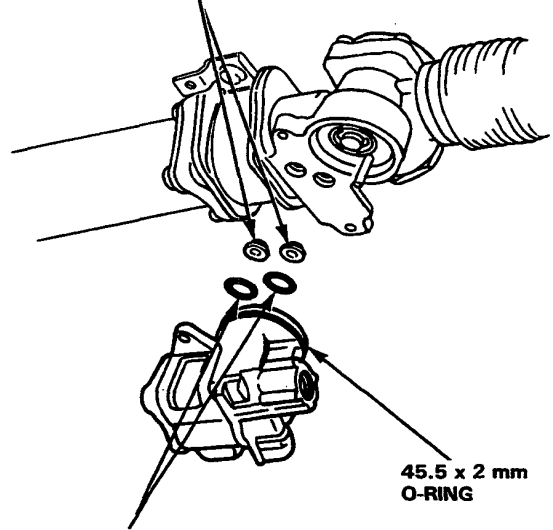

9.8 x 1.9 mm O-RINGS

8. Remove the two 6 mm flange bolts, and remove the cap from the valve body.
9. Remove the port seal from the cap.

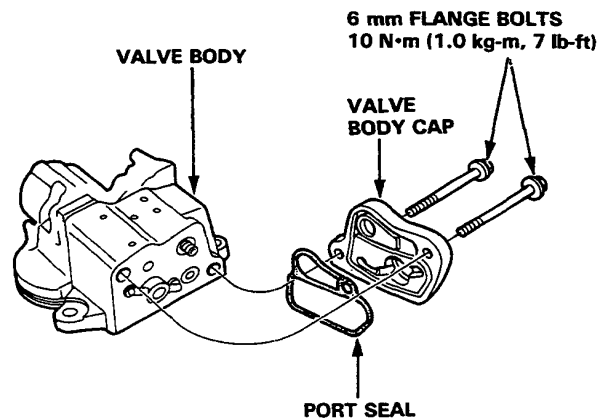



10. Remove the cut-off valve and spring from the valve body.

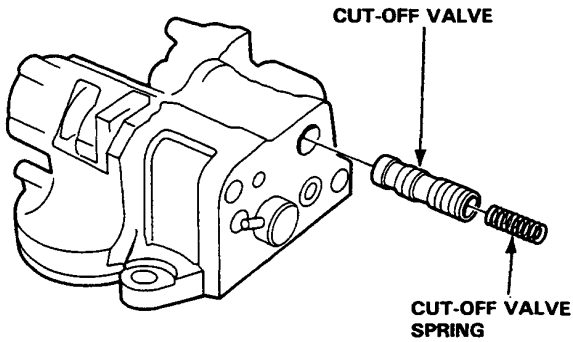

11. Check the cut-off valve:

- Inspect its surface for scoring or scratches.
- Slip it back into the valve body, and make sure it slides smoothly without drag and without side play.

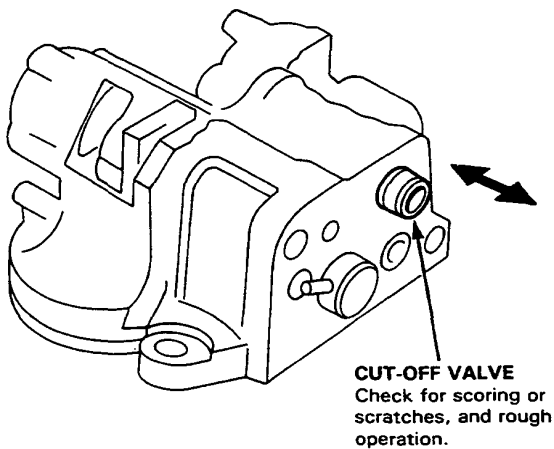

NOTE:

- The cut-off valve is sized to fit the valve body, so, if you replace it, make sure the new valve has the same identification mark on it.
- If the valve body is damaged, replace all three parts (valve body, cut-off valve and control valve) as a set.

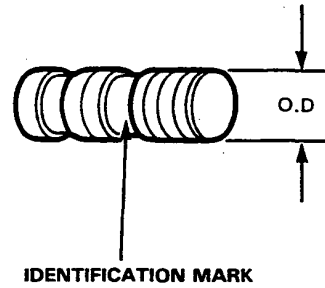

Identification mark	Outside diameter	Part number
A	10.000–10.005 mm (0.3937–0.3939 in.)	53650–SEO–950
B	9.995–10.000 mm (0.3935–0.3937 in.)	53651–SEO–950
C	9.990–9.995 mm (0.3933–0.3935 in.)	53652–SEO–950

12. Separate the valve body and port housing.

13. Remove the port seal and dowel pins from the port housing.

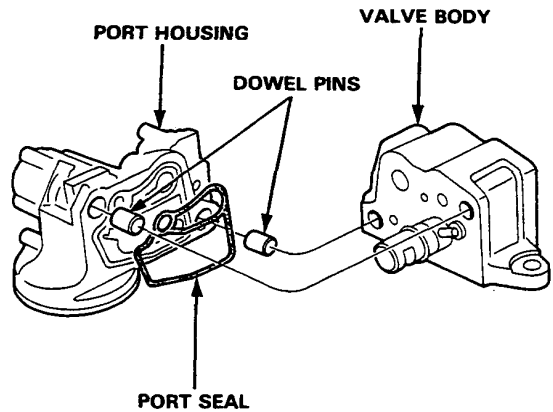

(cont'd)

Steering Gearbox

Valve Body Unit Overhaul (cont'd)

14. Remove the rollers from the control valve by pushing the valve out one side of the valve body, and then the other.

NOTE: When removing the rollers, hold the plungers with your fingers to keep them from popping out.

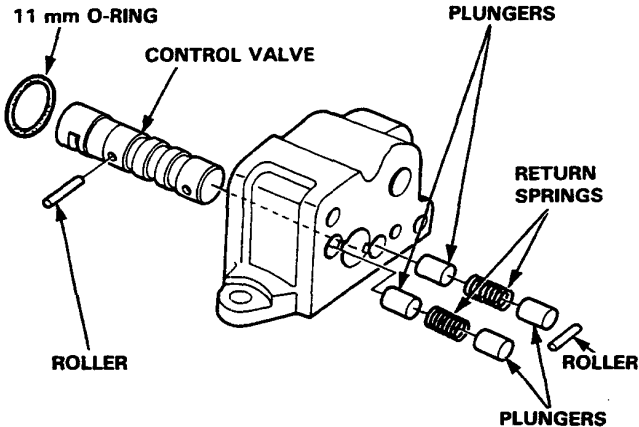

15. Remove the plungers, return springs and control valve from the valve body.
16. Remove the 11 mm O-ring from the control valve.
17. Check the plungers.

- Inspect their surface for scoring or scratches.
- Slip each plunger into the valve body, and make sure it slides smoothly, without drag or side play. If any plunger is damaged, replace it.

NOTE: If the valve body is damaged, replace all three parts (valve body, cut-off valve and control valve) as a set.

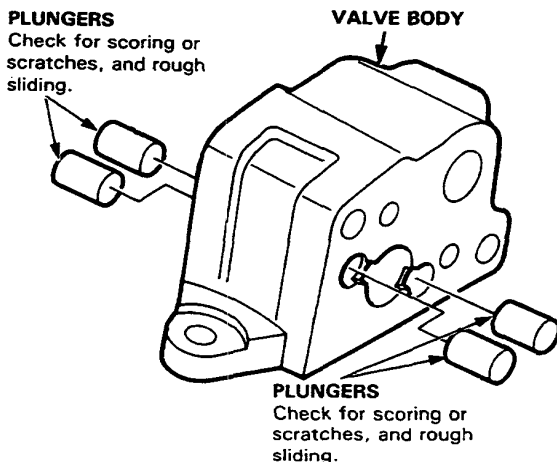

18. Check the control valve.

- Inspect its surface for scoring or scratches.
- Slip it into the valve body, and make sure it slides smoothly, without drag or side play.

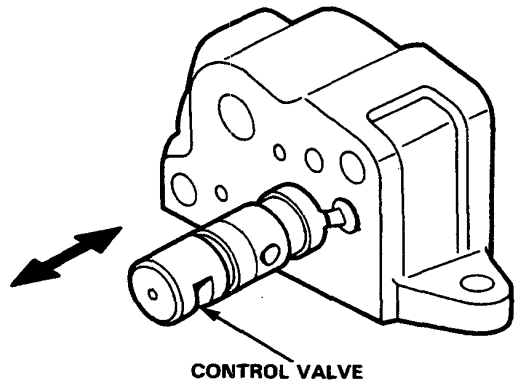

NOTE:

- The control valve is sized to fit the valve body, so, if you replace it, make sure the new valve has the same identification mark on it.
- If the valve body is damaged, replace all three parts (valve body, control valve and cut-off valve) as a set.

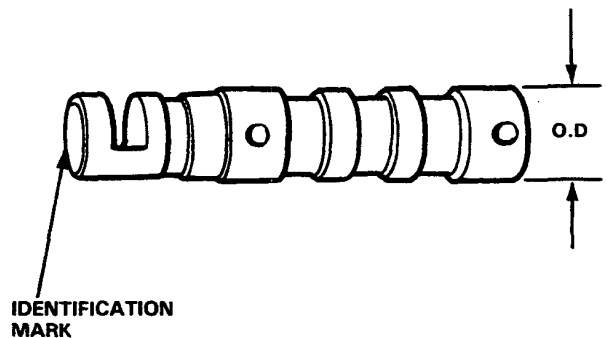

Identification mark	Outside Diameter	Part Number
X	13.998 – 14.003 mm (0.5511 – 0.5513 in.)	53646 – SE0 – 952
Y	13.993 – 13.998 mm (0.5509 – 0.5511 in.)	53647 – SE0 – 952
Z	13.988 – 13.993 mm (0.5507 – 0.5509 in.)	53648 – SE0 – 952



19. Using a 1.5 mm (1/16") drill bit, remove the sensor orifice and O-ring.

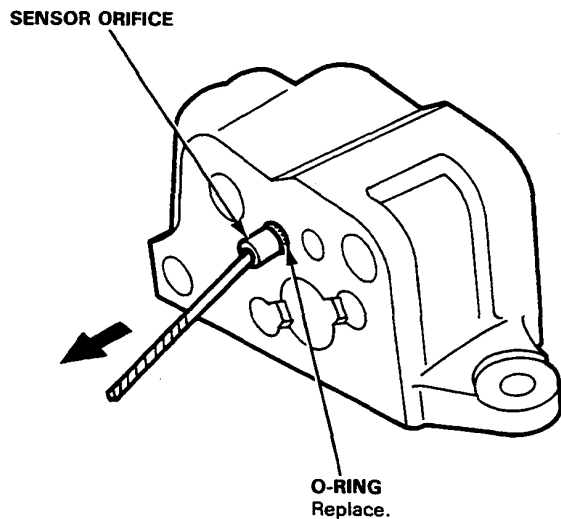

20. Using a 1.5 mm (1/16") drill bit, push the damping orifice and O-ring out of the valve body.

CAUTION: Grind the shank end of the drill bit flat before using.

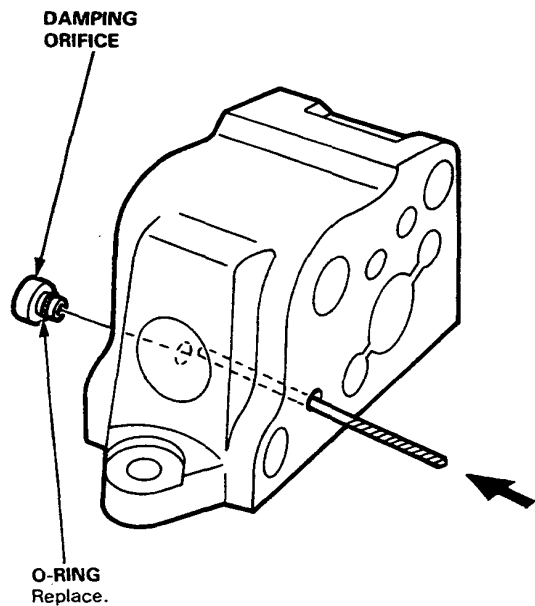

Steering Gearbox

Valve Body Unit Overhaul (cont'd)

Assembly:

1. Thoroughly clean the disassembled parts shown below.
2. Coat the plungers, cut-off valve and reaction control valve surfaces with power steering fluid.
3. Reassemble the parts in reverse order of disassembly.

CAUTION:

- Replace the O-rings and seals with new ones.
- Do not dip the O-rings and seals in solvent.
- Apply grease in the port seal grooves to keep the seals in place.
- Apply grease to the 45.5 x 2 mm and 11 mm O-rings to keep them in place in the valve ports.
-  STEERING GREASE.....Part Number 08740-99969

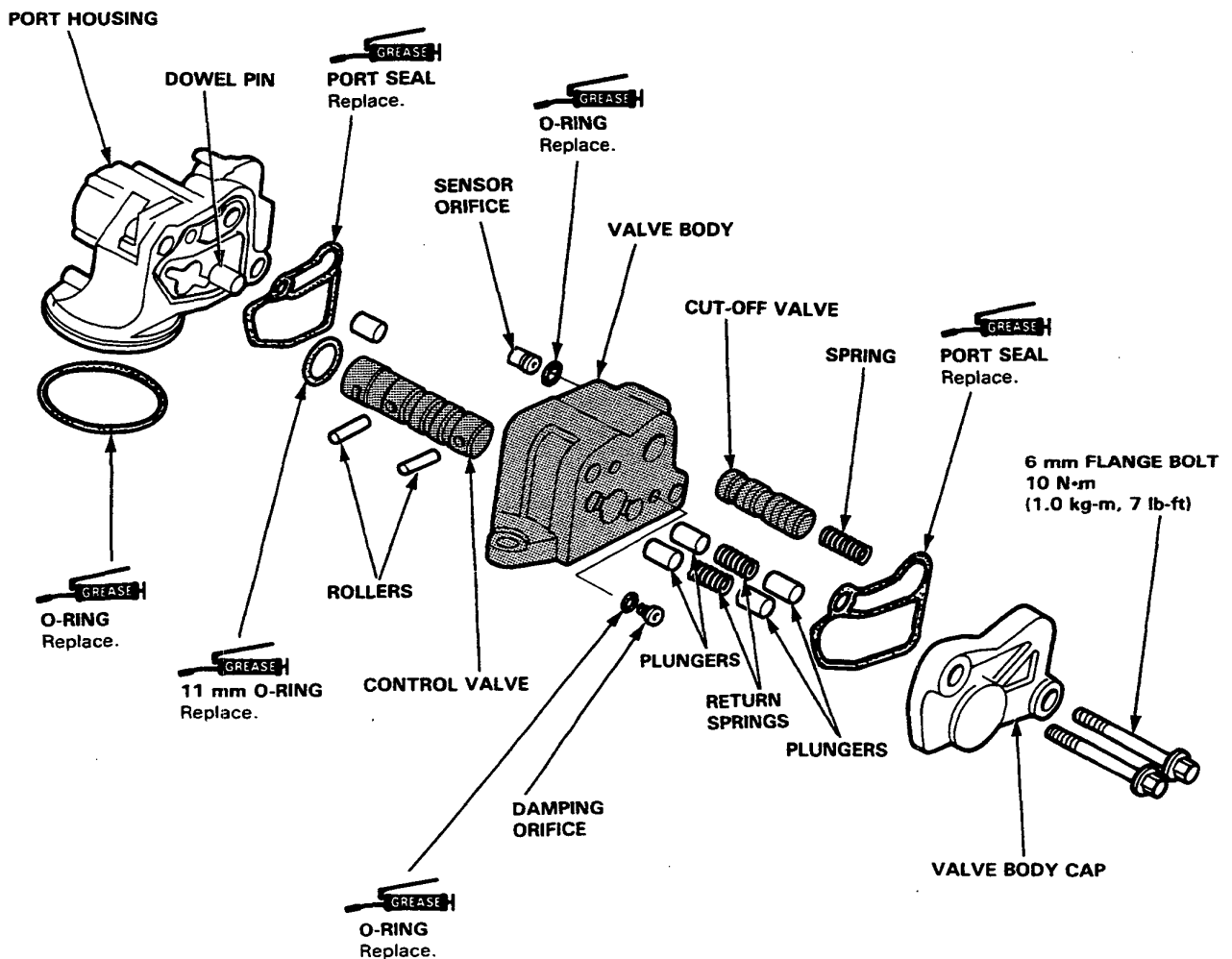

NOTE: If the Valve Body is damaged, it must be replaced as a set, with the Cut-off Valve and Control Valve (shaded parts).



4. Install and tighten the 6 mm flange bolts in the control valve body unit.

CAUTION: Make sure the mating surface of the valve body and cap are flush at the upper side.

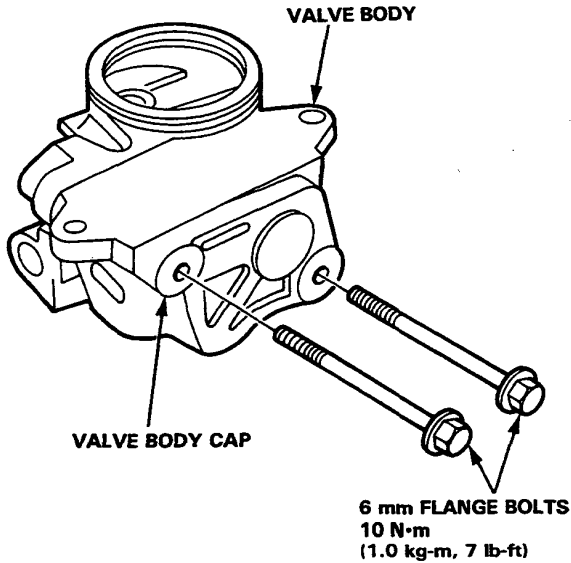

5. Make sure the control valve moves smoothly, and returns to neutral position.

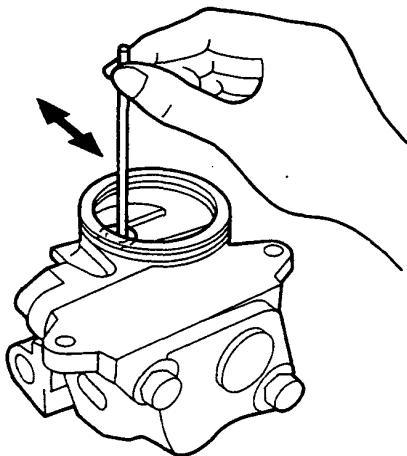

Installation:

6. Coat the 9.8 x 1.9 mm O-rings with grease, and install them together with orifices.

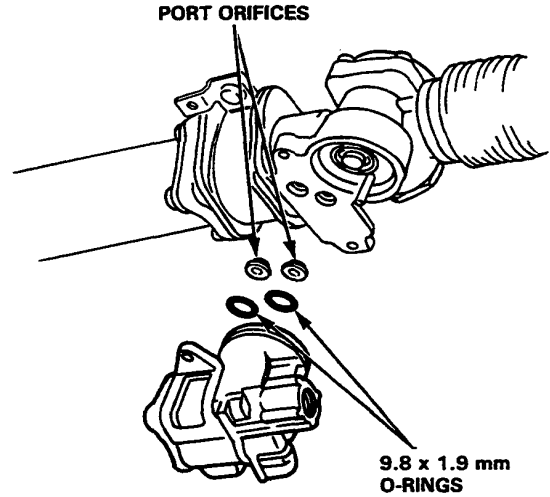

7. Install the valve body unit on the gear housing with the two 6 mm bolts.

CAUTION:

- When installing, be careful not to hit the pinion holder pin.
- Make sure the O-rings are in place and not pinched.

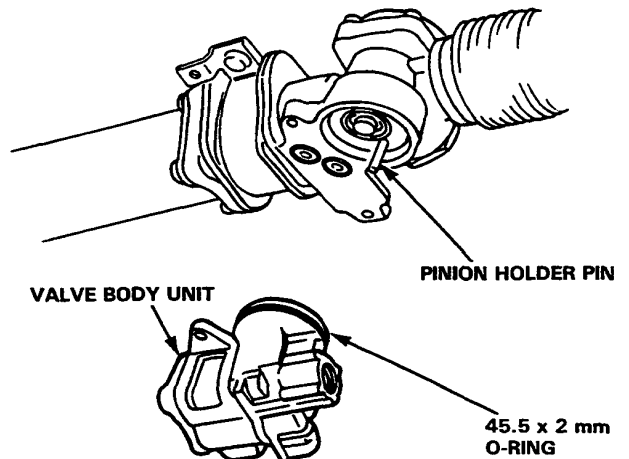

(cont'd)

Steering Gearbox

Valve Body Unit Overhaul (cont'd)

8. Connect the four lines to the control unit, using flare nut wrenches.

- A: From pump: 14 mm wrench
38 N·m (3.8 kg-m, 28 lb-ft)
- B: To speed sensor: 12 mm wrench
13 N·m (1.3 kg-m, 9 lb-ft)
- C: To reservoir: 12 mm wrench
13 N·m (1.3 kg-m, 9 lb-ft)
- D: To oil cooler: 17 mm wrench
29 N·m (2.9 kg-m, 20 lb-ft)

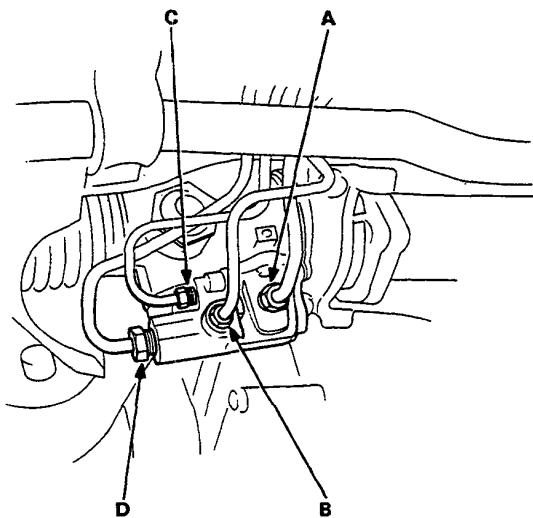

Removal

1. Disconnect the steering joint from the gearbox.

22 N·m (2.2 kg-m, 16 lb-ft)

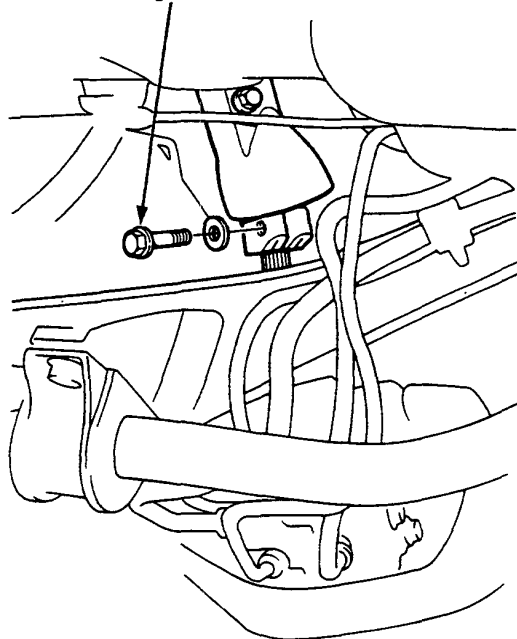

2. Raise the front of car and support on safety stands in the proper locations.
3. Remove the front wheels.
4. Disconnect the tie rods from steering knuckles using the special tool shown.

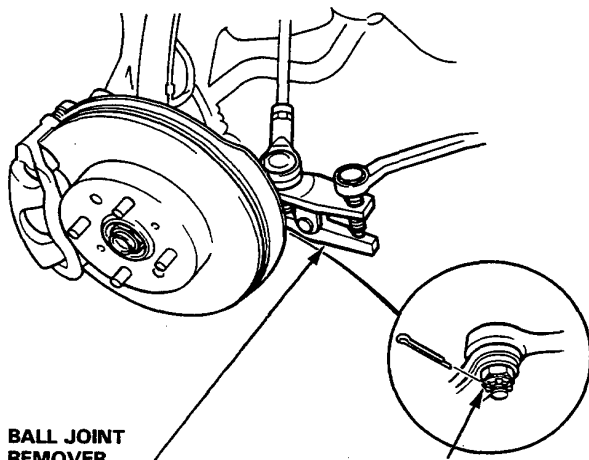

BALL JOINT
REMOVER
07941-6920003

44 N·m (4.4 kg-m, 32 lb-ft)